



# User Manual

**Mini**

**Zoom**

F08GI-5S-BTW

F08GI-5S-Pro

# Table of Contents

- Package Content .....2
- Introduction .....3
- How Signal Boosters Work.....4
- Pre-Installation Instructions.....5
- Installation – Signal Supervisor App .....6
- Installation – Manual Method .....7
- FCC and IC Statements.....16
- Technical Specifications .....17
- Return and Warranty Policies .....18

# Package Content

<b>Product Image</b>		
<b>Product Name</b>	<b>Mini</b>	<b>Zoom</b>
<b>Model Number</b>	F08GI-5S- BTW	F08GI-5S-PRO
<b>Coverage Size</b>	500-2,000 Sq. Ft.	800-3000 Sq. Ft.
<b>Indoor Cable</b>	30 Ft. Low-Loss HiBoost 200 Cable	30 Ft. Low-Loss HiBoost 200 Cable
<b>Outdoor Cable</b>	30 Ft. Low-Loss HiBoost 200 Cable	50 Ft. Low-Loss HiBoost 200 Cable
<b>Indoor Antenna</b>	Indoor Wide-Band Directional Panel Antenna	Indoor Wide-Band Directional Panel Antenna
<b>Outdoor Antenna</b>	Outdoor Wide-Band Directional Panel Antenna	Outdoor Wide-Band Directional Antenna

**Warning:** Un-authorized antennas, cables, and/or coupling devices are prohibited by new FCC rules. Please contact FCC for details: 1(888)-CALL-FCC

## Introduction

Thanks again for purchasing a HiBoost cell phone signal booster. Our cell phone boosters are precision-engineered products that improve cellular reception inside of homes and office by amplifying incoming and outgoing cellular signal.

HiBoost's exclusive cloud-based Signal Supervisor mobile application allow users to monitor the live status of HiBoost cell phone signal boosters remotely from a mobile device anywhere at any time.

If there are any issues while installing a HiBoost cell phone signal booster, please contact the HiBoost technical support team through the following options:

**24/7 Online Support:** Create a ticket or chat via Signal Supervisor App

**Phone:** (972) 870-5666 (M-F from 9 am – 5 pm)

**Email:** [support@hiboostusa.com](mailto:support@hiboostusa.com)

**Website:** [www.hiboost.com](http://www.hiboost.com)

# How Signal Boosters Work

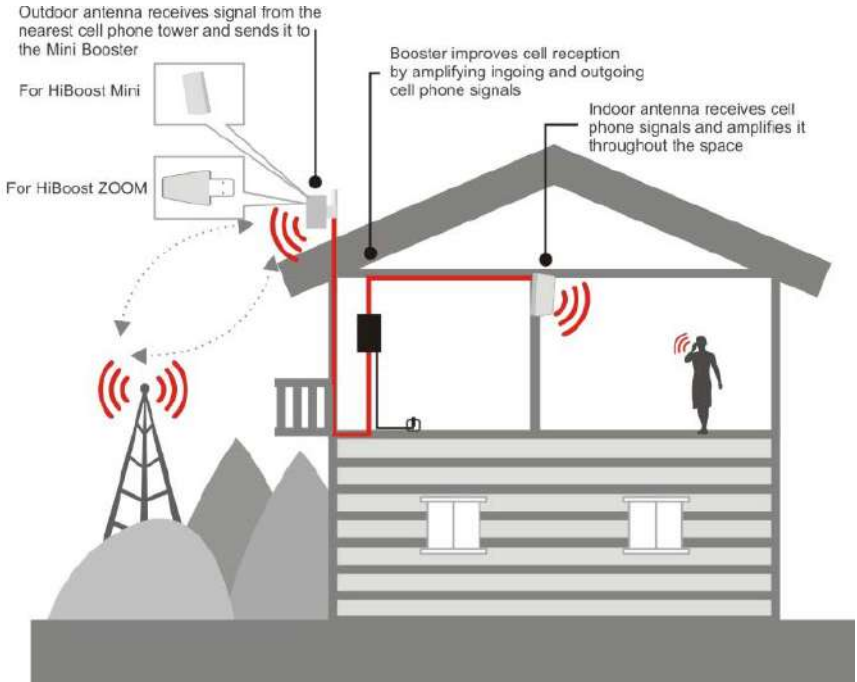

# Pre-Installation Instructions

The cell phone booster and the antennas must be strategically placed in order to perform and provide maximum coverage.

The HiBoost Signal Supervisor app will allow users to communicate to the signal booster via Bluetooth or WiFi. Once registered, the user can remotely monitor the signal booster's performance.

**Note:** Signal Supervisor enabled boosters must have access to a Bluetooth enabled device in order to connect to the booster.

## Professional Installation Tips:

- For a fast and optimized installation, it is strongly recommended that users install HiBoost products using the Signal Supervisor mobile application
- Completely read the user manual and gather all necessary tools, material and accessories before installing the booster
- A “soft installation” is recommended before permanently mounting any equipment – this technique will simplify the installation process by allowing users to identify any potential installation issues beforehand
- The Signal Supervisor App integrates a tool that will help users locate the best location for the outdoor antenna – ensure that there is at least 20 ft of vertical separation between both antennas
- It is important to have a strong and stable WiFi connection to the booster

# Installation – Signal Supervisor App

Before installing the Signal Supervisor App, please have the booster unit that is powered on and nearby.

**Note:** Turn on the Bluetooth feature enabled before attempting to register the booster to the mobile device.

**Step 1:** Download the Signal Supervisor App

- The application is available for download through Apple’s App Store or Google Play

**Step 2:** Create a New Account and Log-in

- Launch the app on your mobile device
- Select the **HiBoost Server**
- Log-in with an existing account create a new one

**Step 3:** Register the Booster by adding a device on the home menu

**Go to My Devices > Add a Device**

**Step 4:** Follow the step-by-step Quick Installation Guide after registering the booster.

You can also access the guide by following:

**Go to My Devices > Select the Booster > Device Details > Quick Install Guide**

**Note:** Bluetooth connections are limited to a range of only 30 feet.

If there are any issues installing the booster, please contact our technical support team via the Online Support Chat.

# Installation – Manual Method

Before beginning the installation, it is important that users survey and plan the layout of the cell phone signal booster system. Please review the following instructions before attempting to install this system.

In this set up, the user will need to use the outdoor antenna to find the strongest source of nearby cellular signal (generally in the direction of the nearest cell phone tower). This will optimize the system by helping user install the booster and antennas in the best position and direction.

- A. Finding the Strongest Outdoor Signal
- B. Install the Booster
- C. Finalize the Installation

## Part A) Outdoor Antenna Installation

There is not an antenna mast included in this kit. If you have question about how to install outdoor antenna, please call our support team at (972) 870-5666. Below are installation instructions on how to install the mounting bracket.

If you buy HiBoost **Mini**, please follow the steps below to install the outdoor antenna with the mounting hardware included in the kit.

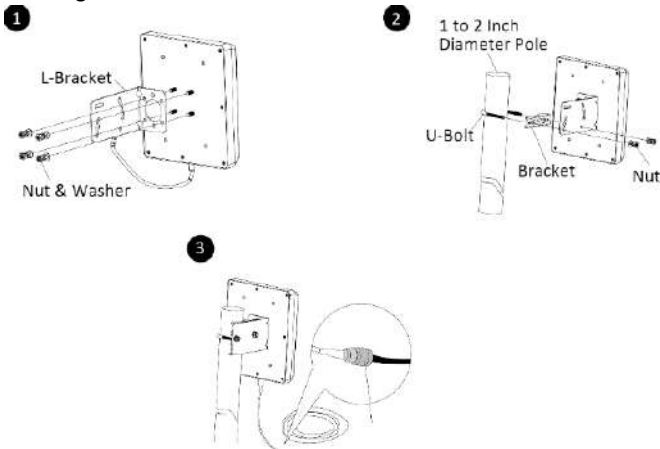



If you buy HiBoost **Zoom**, please follow the steps below to install the outdoor antenna with the mounting hardware included in the kit.

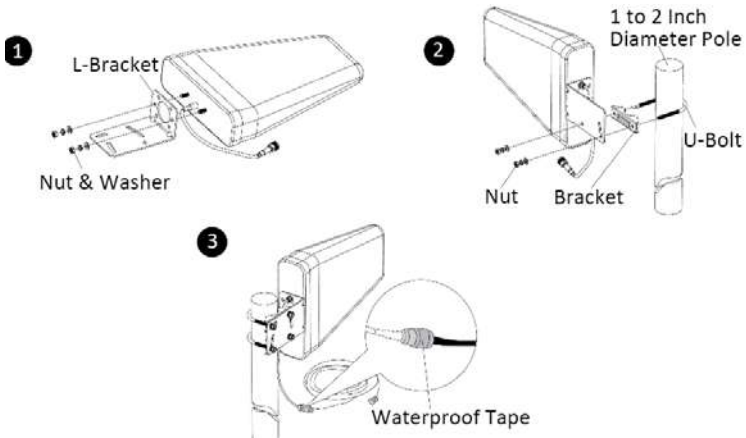

## Part B) Indoor Antenna Installation

While determining where to install the indoor panel antenna, please ensure that there is at least 20 ft of vertical separation between the outdoor and indoor antenna. To avoid any oscillation issues, it is recommended that the outdoor antenna is pointed away from the indoor antenna.

The panel antenna included in this kit will be mounted to the wall. It has a coverage area that is a sector with a tilted angle. The signal is amplified outwards from the front of the indoor antenna at a horizontal angle of 80-degrees. The height between the floor and the indoor antenna can vary.

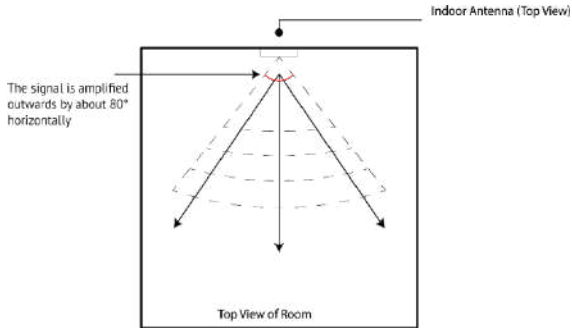

Follow the steps below to install the indoor antenna.

1. Connect the indoor antenna to the booster using the coaxial cable.
2. Push the cable firmly into the jack on both the antenna and the booster, then turn the connector sleeve clockwise until the connectors are tight.
3. Find a location to mount the indoor panel antenna and permanently mount the indoor antenna panel antenna with the hardware provided in the kit.

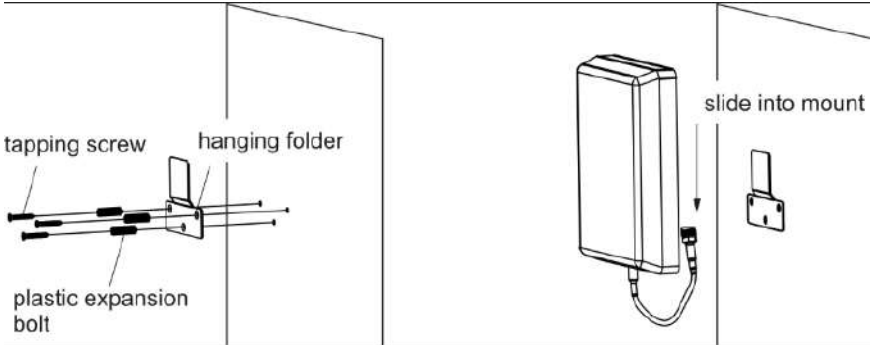

**Note:** It is important that the indoor and outdoor antennas are pointed away from each other.

The outdoor signal strength will affect performance. It is important that users install the outdoor antenna in the right position on a mast that is mounted outside from the roof, balcony or ground.

It may help to visit an online resource such as [www.cellmapper.net](http://www.cellmapper.net), [www.cellreception.com](http://www.cellreception.com) or [www.antennasearch.com](http://www.antennasearch.com)

1. Once the best location is located, use the hardware provided in the kit to mount the outdoor antenna on a mast pointing towards the nearest cell phone tower.
2. Connect the outdoor antenna transmission cable to the coaxial cable provided in the kit, then connect the coaxial cable to the outdoor port on the booster.

**Note:**

- It is easier to optimize the outdoor antenna installation using the Signal Supervisor app since it can determine real-time signal measurements using the outdoor antenna and signal booster.
- Find the best location for the outdoor antenna by using a cell phone to monitor the number of signal bars being received while slowly moving around to different locations.
- It is recommended that users perform multiple tests while moving around to different locations- refresh the signal bar readings by turning off and on airplane mode on the cell phone.
- It is important to gain height above nearby obstructions (such as trees, buildings, etc.) while mounting the outdoor antenna on mast.

## Part C) Finalize the Booster Installation

Finalize the booster installation by following the steps below:

1. Users can mount or place the signal booster in a dry and cool area that is easily accessible for maintenance as below (it should be located near a power outlet).

*Booster Installation diagram for HiBooster Mini and Zoom:*

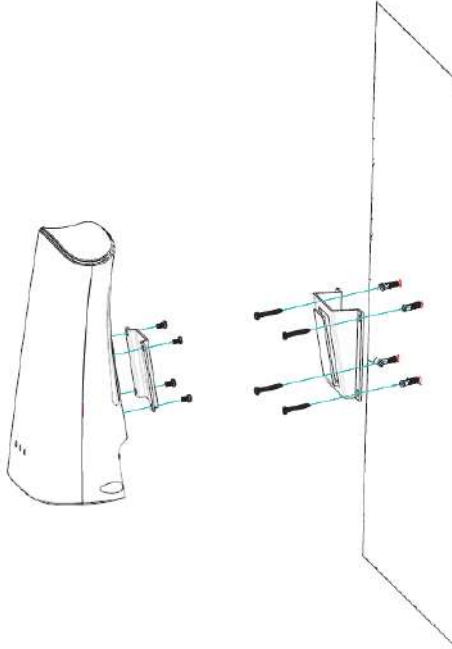

2. Loosely run the coaxial cable from the indoor and outdoor antenna to the signal booster and secure all connections in the correct port

### *Professional tips*

- *Be careful while routing and bending cable – protect the connector by wrapping and securing a towel around the end of the cable*
  - *Keep horizontal cables straight and secure with zip-ties every 3-5 feet*
  - *Keep vertical cables straight and secure with zip-ties every 6-8 feet*
  - *Avoid water damage by using the waterproof tape provided in the kit on the connector attached to the outdoor antenna transmission cable*
  - *Be careful and avoid damaging the pins in the center of the connectors while attaching cables*
3. Carefully plug in the power supply to the booster port marked 'DC 12V'

**Note:** For safety purposes, it is recommended to use a 1,000 Joule surge protector between the booster's power supply and AC power outlet

4. Check to see if all LED indicators are green and that all the following parameters are met:
- ✓ There are at least 20 feet worth of vertical separation in between the indoor and outdoor antennas
  - ✓ The front of the outdoor antenna is **NOT** facing towards the front of the indoor antenna
  - ✓ All coaxial cable connections to the antennas and booster are properly connected

# Troubleshooting Guide

## **Eliminate ISO LED Indicator Quick Flashing Blue, Quick Flashing Red problems:**

1. Adjust the outdoor antenna direction, keep it away from the indoor antenna – restart the booster
2. Increase the vertical or horizontal distance between the outdoor antenna and the indoor antenna – restart booster
3. Use metal or wall barriers to increase the isolation between the indoor and outdoor antennas – restart booster
4. Change the indoor antenna type to an antenna with a more directional antenna pattern – orient the indoor antenna and the outdoor antenna so they are not pointing at each other

The ISO issues are solved when the ISO LED is “Blue” or “Slow Flashing Blue”.

## **If the signal has not been improved, please check below:**

- A weak downlink signal leads to the low output signal level – change the direction or position of the outdoor antenna (check downlink gain levels using the Signal Supervisor app)
- Try replacing the outdoor antenna with a higher gain antenna to increase the amount of signal being received
- Check to see if it is necessary to adjust the position of the indoor antenna – barriers such as walls can block the signal indoors
- Ensure that there are at least 20 feet of vertical separation between the indoor and outdoor antenna
- Ensure that the indoor and outdoor antennas are facing away from each other
- Check the booster to make sure the output power is maximized – the user may need to replace the booster with a more powerful one if the amount of outdoor signal available is limited

## Other Troubleshooting Issues

You may reference the chart below to identify the current status of your booster:

LED STATUS INDICATORS		
Alarm (ISO) LED	SOLID BLUE	BELOW FULL OUTPUT POWER
	SLOW FLASHING BLUE	FULL OUTPUT POWER
	QUICK FLASHING BLUE	OUTPUT POWER IS TOO HIGH
	QUICK FLASHING RED	BOOSTER SHUT DOWN - EXCESSIVE DOWNLINK SIGNAL
Bluetooth LED	SLOW FLASHING BLUE	BLUETOOTH DISCONNECTED
	QUICK FLASHING BLUE	BLUETOOTH CONNECTED
Wi-Fi LED	SOLID BLUE	WIFI DISCONNECTED
	SLOW FLASHING BLUE	WIFI CONNECTED

If you have any issues installing your HiBoost Booster, please contact our technical support team.

**24/7 Online Support:** Create a ticket or chat via Signal Supervisor App

**Phone:** (972) 870-5666 (M-F from 9 am – 5 pm)

**Email:** [support@hiboostusa.com](mailto:support@hiboostusa.com)

**Website:** [www.hiboost.com](http://www.hiboost.com)

# Authorized Accessories List

## Outdoor Antenna & Cable Kit Options

### Kit 9-5050

Yagi 9dbi Antenna & 50' 5D Cable

### Kit 11-100400

Yagi 11dbi Antenna & 100' 400 Cable

### Kit 11-7550

Yagi 11dbi Antenna & 75' 5D Cable

### Kit 11-100500

Yagi 11dbi Antenna & 100' 5D Cable

### Kit 10-3050

Panel 10dbi Antenna & 30' 5D Cable

### Kit 10-50400

Panel 10dbi Antenna & 50' 400 Cable

### Kit 10-5050

Panel 10dbi Antenna & 50' 5D Cable

### Kit 10-75400

Panel 10dbi Antenna & 75' 400 Cable

### Kit 10-100400

Panel 10dbi Antenna & 100' 400 Cable

### Kit 10-7550

Panel 10dbi Antenna & 75' 5D Cable

### Kit 10-10050

Panel 10dbi Antenna & 100' 5D Cable

### Kit 9-50400

Yagi 9dbi Antenna & 50' 400 Cable

### Kit 9-75400

Yagi 9dbi Antenna & 75' 400 Cable

### Kit 9-100400

Yagi 9dbi Antenna & 100' 400 Cable

### Kit 9-7550

Yagi 9dbi Antenna & 75' 5D Cable

### Kit 9-10050

Yagi 9dbi Antenna & 100' 5D Cable

### Kit 7-3050

Panel 7dbi Antenna & 30' 5D Cable

### Kit 7-50400

Panel 7dbi Antenna & 50' 400 Cable

### Kit 7-5050

Panel 7dbi Antenna & 50' 5D Cable

### Kit 7-75400

Panel 7dbi Antenna & 75' 400 Cable

### Kit 7-100400

Panel 7dbi Antenna & 100' 400 Cable

### Kit 7-7550

Panel 7dbi Antenna & 75' 5D Cable

### Kit 7-10050

Panel 7dbi Antenna & 100' 5D Cable

### Kit 5-30400

Omni 5dbi Antenna & 30' 400 Cable

### Kit 5-3050

Omni 5dbi Antenna & 30' 5D Cable

### Kit 5-50400

Omni 5dbi Antenna & 50' 400 Cable

### Kit 5-5050

Omni 5dbi Antenna & 50' 5D Cable

### Kit 5-75400

Omni 5dbi Antenna & 75' 400 Cable

### Kit 5-10400

Omni 5dbi Antenna & 100' 400 Cable

### Kit 5-7550

Omni 5dbi Antenna & 75' 5D Cable

### Kit 5-10050

Omni 5dbi Antenna & 100' 5D Cable

## Indoor Antenna & Cable Kit Options

### Kit 72-5050-50

2 Panel 7dbi Antenna with 50' 5D N male & 2-Way Splitter

### Kit 52-5050-50

2 Whip 5dbi Antenna & 50' 5D Cable & 2-Way Splitter

### Kit 102-5050-50

2 Panel 10dbi Antenna with 50' 5D N male & 2-Way Splitter

### Kit 103-7550-50

3 Panel 10dbi Antenna & 75' 5D Cable & 3-Way Splitter

### Kit 104-7550-50

4 Panel 10dbi Antenna & 75' 5D Cable & 3 2-Way Splitter

### Kit 73-7550-50

3 Panel 7dbi Antenna & 75' 5D Cable & 3-Way Splitter

### Kit 74-7550-50

4 Panel 7dbi Antenna & 75' 5D Cable & 3 2-Way Splitter

### Kit 3-30400

Omni 3dBi Antenna with 30' 400 Cable

### Kit 3-5050

Omni 3dBi Antenna & 50' 5D Cable

### Kit 3-7550

Omni 3dBi Antenna & 75' 5D Cable

### Kit 3-10050

Omni 3dBi Antenna & 100' 5D Cable

### Kit 3-30400

Omni 3dBi Antenna with 30' 400 Cable

### Kit 3-50400

Omni 3dBi Antenna & 50' 400 Cable

### Kit 32-50400-50

2 Omni 3dBi Antenna & 50' 400 Cable

### Kit 32-50400-50

2 Omni 3dBi Antenna & 50' 400 Cable

### Kit 33-50400-50

3 Omni 3dBi Antenna & 50' 400 Cable

### Kit 34-50400-50

4 Omni 3dBi Antenna & 50' 400 Cable

### Kit 34-50400-50

4 Omni 3dBi Antenna & 50' 400 Cable & 3 2-Way Splitter



# FCC and IC Statements

## FCC RF EXPOSURE STATEMENT

This equipment complies with FCC radiation exposure limits set forth for an uncontrolled environment. End users must follow the specific operating instruction for satisfying RF exposure compliance. This transmitter must not be co-located or operating in conjunction with any other antenna or transmitter.

## IC RF EXPOSURE STATEMENT

The device is compliance with RF exposure limits. The minimum distance from body to use the device is 20 CM.

Le présent appareil est conforme aux conformité ou aux limites d'intensité de champ RF. La distance minimale du corps à utiliser le dispositif est de 20 CM.

This equipment has been tested and found to comply with the limits for a Class B digital device, pursuant to part 15 of the FCC Rules. These limits are designed to provide reasonable protection against harmful interference in a residential installation. This equipment generates, uses and can radiate radio frequency energy and, if not installed and used in accordance with the instructions, may cause harmful interference to radio communications. However, there is no guarantee that interference will not occur in a installation. If this equipment does cause harmful interference to radio or television reception, which can be determined by turning the equipment off and on, the user is encouraged to try to correct the interference by one or more of the following measures:

- Re-orient or relocate the receiving antenna.
- Increase the separation between the equipment and receiver
- Connect the equipment into an outlet on a circuit different from that to which the receiver is connected
- Consult the dealer or an experienced radio/TV technician for help

Changes or modifications not expressly approved by HiBoost could void the user's authority to operate the equipment. For a complete list of antennas and cables approved for use with these boosters see Authorized Kitting Options

**FCC 27.50(d)(4) Statement:** Fixed, mobile, and portable (handheld) stations operating in the 1710-1755 MHz band are limited to 1-watt EIRP. Fixed stations operating in the 1710-1755 MHz band are limited to a maximum antenna height of 10 meters above ground.

## FURTHER INFORMATION ON SIGNAL BOOSTER END-USE REGISTRATION

The following links are the currently active contacts for booster registration with U.S. wireless providers:

<https://www.uscellular.com/uscellular/support/fcc-booster-registration.jsp>  
[https://www.sprint.com/legal/fcc\\_boosters.html](https://www.sprint.com/legal/fcc_boosters.html)  
<https://www.verizonwireless.com/solutions-and-services/accessories/register-signal-booster/>  
<https://support.t-mobile.com/docs/DOC-9827>  
<https://securec45.securewebsession.com/attnsignalbooster.com/>

**IC Statement:** This device complies with Innovation, Science and Economic Development Canada ICES-003 Compliance Label: CAN ICES-3 (B)/ NMB-3(B). Le présent appareil est conforme Innovation, science et développement économique Canada ICES-003 Étiquette de conformité: CAN ICES-3 (B) / NMB-3 (B).

Please follow the link to access the CPC-2-1-05:

<http://www.ic.gc.ca/eic/site/smt-gst.nsf/eng/sf08942.html>

This is a **CONSUMER** device.

**BEFORE USE**, you **MUST REGISTER THIS DEVICE** with your wireless provider and have your provider's consent. Most wireless providers consent to the use of signal boosters. Some providers may not consent to the use of this device on their network. If you are unsure, contact your provider.

In Canada, BEFORE USE, you must meet all requirements set out in ISED CPC-2-1-05.

You **MUST** operate this device with approved antennas and cables as specified by the manufacturer. Antennas **MUST** be installed least 20 cm (8 inches) from (i.e., **MUST NOT** be installed within 20 cm of) any person.

You **MUST** cease operating this device immediately if requested by the FCC (or ISED in Canada) or a licensed wireless service provider.

**WARNING.** E911 location information may not be provided or may be inaccurate for calls served by using this device.

This device may be operated **ONLY** in a fixed location (i.e., may operate in a fixed location only) for in-building use.

# Technical Specifications

## Mini and Zoom Specifications

Working Band	Band 12/17 / Band 13 / Band 5 / Band 25/2 / Band 4
UL Frequency Range(MHz)	698-716 / 776 – 787 / 824-849 / 1850-1915 / 1710-1755
DL Frequency Range(MHz)	728-746 / 746 – 757 / 868-894 / 1930-1995 / 2110-2155
Supported Standards	CDMA, WCDMA, GSM, EDGE, HSPA+, EVDO, LTE and all cellular standards
Max. Gain	65 dB
Max. Output Power	UL 18 dBm, DL 10 dBm
I/O Port	N-Female
Impedance	50 ohm
Environment Conditions	IP40
Dimensions	7.6*4.5*3 inch / 193* 115* 76mm
Weight	≤ 3.3lbs / 1.5kg
Power Supply	Input AC100~240 V, 50/60 Hz, Output DC 12 V / 3 A

## Return and Warranty Policies

**30-Day Money-Back Guarantee:** If for any reason the performance of any product is not acceptable, the product may be returned to the reseller within 30-days with proof of purchase. Please contact the HiBoost customer support.

**3-Year Warranty:** HiBoost signal boosters and kits are warranted for 3 years. HiBoost will repair or replace the unit and will cover the cost of delivery for consumers located within the continental U.S and Canada.

Customers can choose to return the signal boosters and kits directly to the manufacturer at the purchaser's expense with a dated proof of purchase and a Returned Material Authorization (RMA) number supplied by HiBoost. RMA numbers may be obtained by contacting customer support at 972-870- 5666 or support @hiboostusa.com

This warranty does not apply to any signal boosters or kits determined by HiBoost to have been subjected to tampering, misuse, abuse, neglect, or mishandling that alters or damages physical or electronic properties.

HiBoost is not liable for any Signal Supervisor application network connectivity issues. The cell phone signal booster relies on a strong, continuous and reliable connection to the internet in order to communicate with the cell phone application. For all Signal Supervisor Application related issues, please check your network strength and call our technical support.

All HiBoost products that are packaged with other HiBoost accessory products are intended for resale and used as a single integrated system. Such product kits are required to be sold to the end-users or subsequent reseller as packaged.





HiBoost  
6210 N Beltline Rd. #110  
Irving, TX 75063  
(972) 870-5666  
support@hiboostusa.com  
www.hiboost.com