

# User Manual

Home Mobile Signal Booster

Mini Series

Hero

3150 Premier Drive, Suite 130,  
Irving, TX 75063  
(972) 870-5666  
service@hiboost.com  
www.hiboost.com





# CONTENTS

|                                     |    |
|-------------------------------------|----|
| Package Content .....               | 01 |
| Introduction .....                  | 02 |
| Pre-Installation Instructions ..... | 03 |
| Notes about LCD Display .....       | 08 |
| APP Assisted Installation .....     | 10 |
| LCD Assisted Installation .....     | 25 |
| Quick Troubleshooting Guide .....   | 38 |
| Technical Specifications .....      | 39 |
| Authorized Accessories List .....   | 40 |
| FCC and IC Statements .....         | 41 |
| Return and Warranty Policies .....  | 43 |



Signal Booster



Indoor Whip Antenna



1\*32.8' Outdoor Cable(NM-SMAM)  
1\*16.4' Outdoor Cable(SMAF-SMAM)  
1\*30' Indoor Cable(SMAM-NM)



Outdoor Antenna



Indoor Panel Antenna



Through-window Cable (SMAM-SMAF)



Power Supply



Waterproof Tape

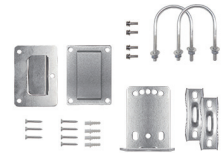

Other Accessories

Note: Available accessories can be purchased through [HiBoost.com](http://HiBoost.com)

Warning: Un-authorized antennas, cables, and/or coupling devices are prohibited by new FCC rules, Please contact FCC for details: 1(888)-CALL-FCC.

# Introduction

Thanks again for purchasing HiBoost cell phone Booster. Hero booster of Mini series is a collection of precision-engineered product that improves cellular reception inside of homes and businesses by amplifying incoming and outgoing cell phone signals.

HiBoost cell Booster's exclusive cloud-based Signal Supervisor mobile application and LCD display allow users to monitor the live status of HiBoost cell phone signal boosters directly from the LCD display or remotely from a mobile device anywhere at any time.

If there are any issues while installing a HiBoost cell phone signal booster, please contact the HiBoost technical support team through the following options:

**Online Support:** Create a ticket or chat via Signal Supervisor App

 (972) 870-5666 (M-F from 9 am – 5 pm CST)

 [service@hiboost.com](mailto:service@hiboost.com)

 [www.hiboost.com](http://www.hiboost.com)

# Pre-Installation Instructions

We strongly recommend you to read the user guide completely before you install.

HiBoost Hero provides 2 options of booster installation, APP and LCD installation ways are unique methods provided by HiBoost.

## 1. APP Assisted Installation: **FIRST CHOICE From Page 10~24.**

It's more convenient and many work could be done by ONE person, and the most important is that the obtained signal can be very precise.



## 2. LCD Assisted Installation: **SECOND CHOICE From Page 25~37.**

It can achieve the same precise effect as App guidance. But it may need two people and the installation process is a little cumbersome.

LCD signal meter tells how strong the signal is.

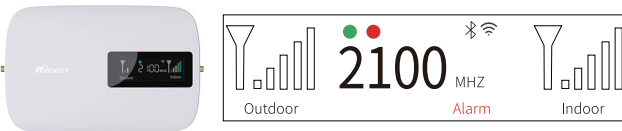



## Then why has HiBoost spent extra big efforts and costs to design APP and LCD signal meters to help you install?

Out of the various reasons, the most important reason is that we would like you, our valuable client, to get the maximum output power from the booster system in order to get optimal signal reception for all your mobile devices.

 As it is known and a big thanks, FCC makes signal boosters legal in 2014 so that every body can install and benefit from the signals;

 But FCC regulations do limit the gain and output power of all consumer boosters to low values in order to avoid any interference to the cell towers;

 Furthermore FCC stipulates that any improper install should trigger immediately further reduction of the booster's already-limited gain and power to protect the towers.

 Therefore, you can understand how important you need to find the perfect outside signal from the tower and how important to squeeze every last gain and power from the booster, even 1dB more power is so precious when you suffer from no signals.

HiBoost App & LCD signal meters will help you to fine tune the best power and get as much cover of your spaces.

## General Working Principle:

Before we start any of the two ways, please allow us to spend 3 pages to make you understand how the booster system works for you.

※ Please do spend sometime to read it fully, as it is crucial to get full bars for your rooms.

## How HiBoost booster works

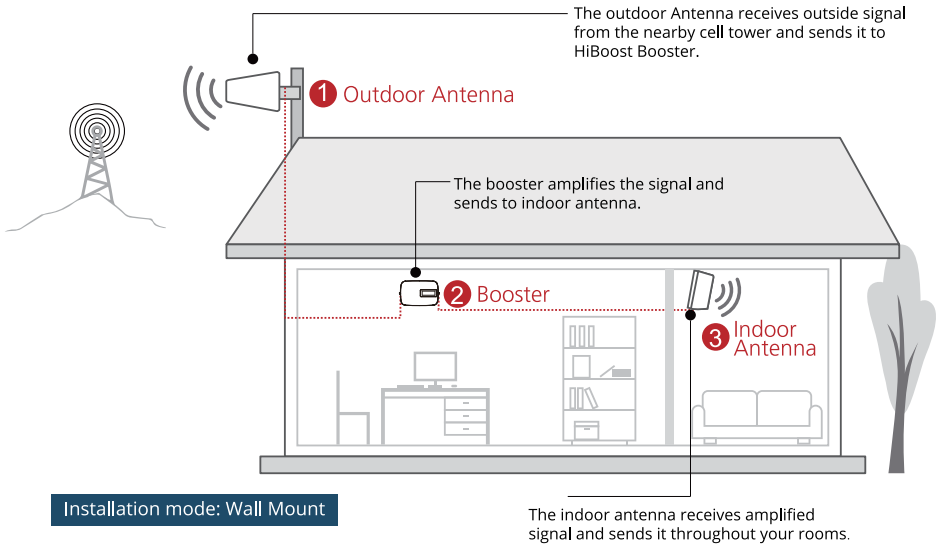
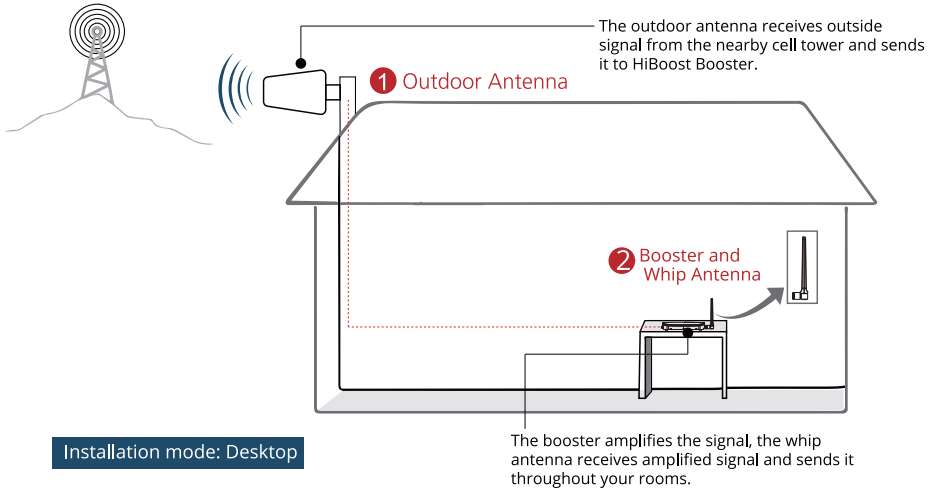

## Working Principle in Formula

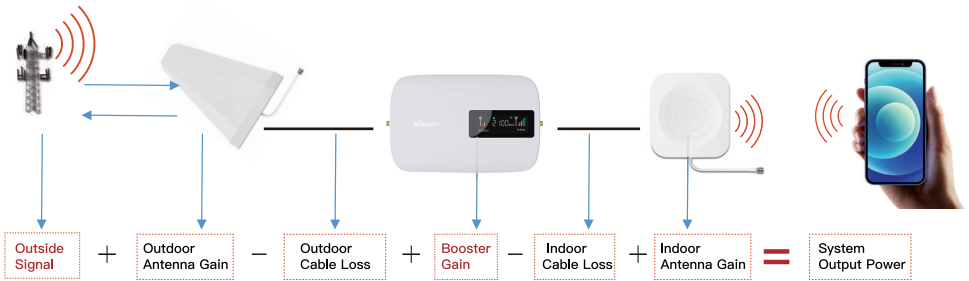

Out of the Formula:

**Outside Signal:** To be received by outdoor antenna from cell tower

**Outdoor Antenna Gain:** The gain of outdoor antenna

**Outdoor Cable Loss:** The loss of the outdoor cable

**Booster Gain:** The actual working gain of the booster

**Indoor Cable Loss:** The loss of the indoor cable

**Indoor Antenna Gain:** The gain of indoor antenna

### For example:

**-70dBm + 11dBi - 4.5dB + 65dB - 2dB + 7dBi = 6.5dBm (System Output Power)**

Since the figures in **Black** color are fixed when you finish the purchase, thus the **RED** figures of

**1. Outside Signal**

**2. Booster Gain** will play a vital role in reaching the best output power during the install, especially when we know the FCC limits the booster system values.

So the user guide is focused on:

1. Getting the best outside signal.
2. Keeping the maximum booster gain.



# More notes on how to keep the maximum booster gain

The loop back from the outdoor antenna to the indoor antenna will reduce the gain, so the principle to keep the maximum booster gain is to avoid the loop back from the outdoor antenna to the indoor antenna.

1) Increase the distance between the outdoor and indoor antenna, generally the same vertical distance generates more loss than horizontal, and to follow easily, a Typical Required Distance Between Outdoor and Indoor Antenna Over 30 feet (10 meters) horizontal distance or 13 feet (4 meters) vertical distance.

2) The outdoor and indoor antennas should face opposite directions(panel antenna)

3) Use barriers between the indoor and outdoor antenna.

※ Please note: This separation is not an absolute mandate. The idea is to isolate the outdoor antenna from the indoor antenna.

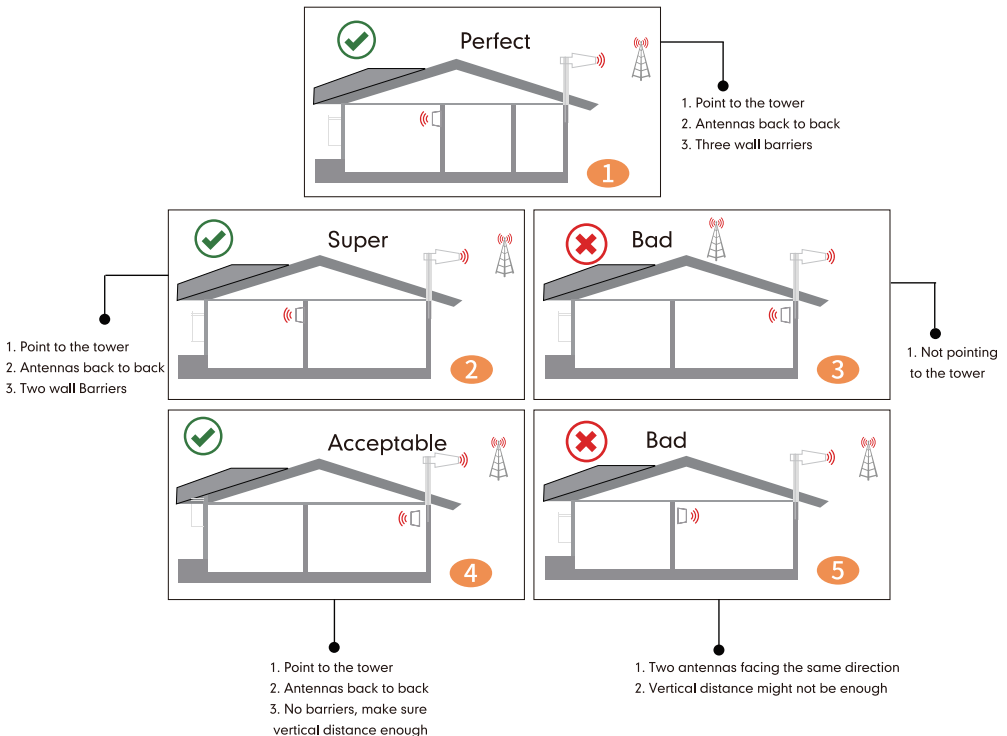

# Notes about LCD Display

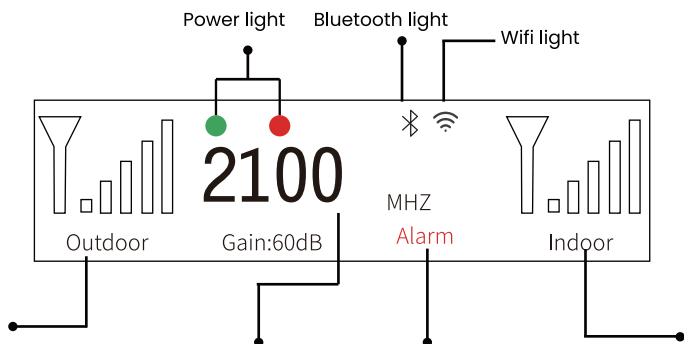

The number of bars indicates the performance of the device. If it shows zero bar, you can try to change the installation position and direction of the outdoor antenna to gain better signal.

It shows the frequency bands' real-time working performance.

When it flashes, it indicates that the device is not working correctly due to oscillation or overload. You can refer to "Quick Troubleshooting Guide" in the latter part of this guide to solve corresponding problems.

It shows the boosted signal strength. The number of bars indicates the performance of the device.

## Indicator Lights

| LED Type  | LED condition | Remark                                              |
|-----------|---------------|-----------------------------------------------------|
| Bluetooth | On            | Successfully connected to Bluetooth                 |
|           | OFF           | Bluetooth is not connected                          |
| Wi-Fi     | On            | Successfully connected to Wi-Fi                     |
|           | OFF           | Wi-Fi is not connected                              |
| Power     | Solid Green   | Normal operating condition                          |
|           | Solid Red     | Booster is working abnormally                       |
|           | OFF           | Booster is not receiving power from DC power supply |
| Alarm     | OFF           | Booster is working normally                         |
|           | Flashing      | Booster is working abnormally                       |

## Bands contained in the Gauges

| Gauge | Band  | Uplink       | Downlink     |
|-------|-------|--------------|--------------|
| 700   | 12/17 | 698-716MHz   | 728-746MHz   |
|       | 13    | 776-787MHz   | 746-757MHz   |
| 800   | 5     | 824-849MHz   | 869-894MHz   |
| 1900  | 25/2  | 1850-1915MHz | 1930-1995MHz |
| 2100  | 4     | 1710-1755MHz | 2110-2155MHz |

Please focus on the gauge that contains the band you are using.

# APP Assisted Installation

## Flow chart of APP Assisted Installation

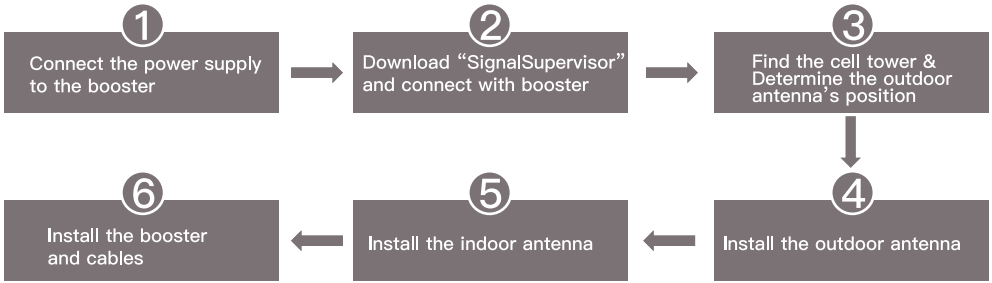

### Step 1: Connect the Power Supply to the Booster



Power Supply



Booster

## Step 2: Download Signal Supervisor APP and connect the booster

Download the Signal Supervisor App, register ID and booster.



- 1) Search "Signal Supervisor" on Google Play/ App Store, or scan the above QR Code to download.
  - 2) Register on the Signal Supervisor APP.
  - 3) Power on the booster
- \* The Bluetooth/WiFi antenna is of built-in type,  
\* There is no need to connect outdoor or indoor antennas at this moment.
- 4) Click "Add Device" to register the booster into the APP. And we recommend WiFi connection because the Bluetooth connection can't go beyond 30ft. Check more steps about the App uses as below.

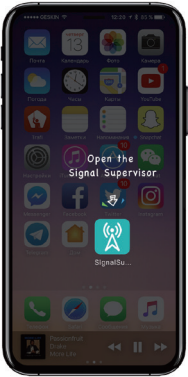

1

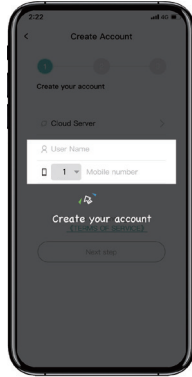

2

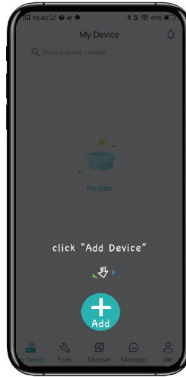

3



4

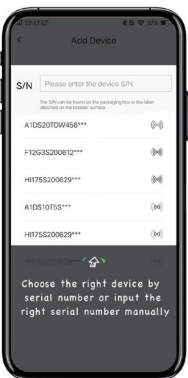

5

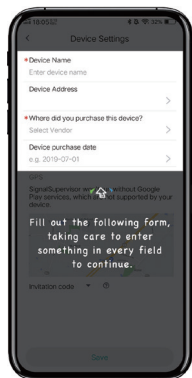

6

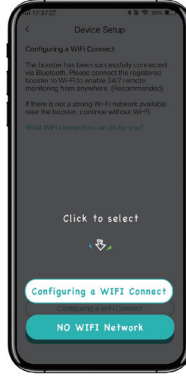

7

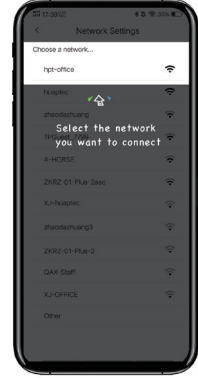

8

## Bands contained in the Gauges on Signal Supervisor

| Gauge   | Band  | Uplink       | Downlink     |
|---------|-------|--------------|--------------|
| LTE700  | 12/17 | 698-716MHz   | 728-746MHz   |
|         | 13    | 776-787MHz   | 746-757MHz   |
| CELL800 | 5     | 824-849MHz   | 869-894MHz   |
| PCS1900 | 25/2  | 1850-1915MHz | 1930-1995MHz |
| AWS2100 | 4     | 1710-1755MHz | 2110-2155MHz |

Please focus on the gauge that contains the band you are using.

Remark: Due to the variety of phone models and the WiFi router types, there is a situation, though it is rare, where the booster cannot be linked to the Signal Supervisor app successfully. If such situation is encountered:

- \* You can alternatively use LCD signal meter to assist your installation. And Bluetooth/Wi-Fi disconnection won't influence the booster working status at all.
- \* Or please use another cell phone or change a WiFi router if you insist an app assisted installation.

Please contact our tech support if you have difficulties in installation, and we will provide the best solution for you.

## Step 3: Find the cell tower & Determine the outdoor antenna's position

### 3.1 Find the band you are using

For Android

Download NetWork Cell Info Lite in the Google store and open it.

It can be seen from the example picture that the frequency band is band 13.

(According to the form before, you need to pay attention to Gauge LTE700)

Then click MAP. You can see your phone connecting to a tower, and you can try aiming your outdoor antenna at it. But sometimes this is not accurate. You could also move to Step 3.2 to find the tower

Note: Please take screenshots at this stage.



For ios

(1)Dial \*3001#12345#\*

(2)Follow the instructions, take the screenshot as required.

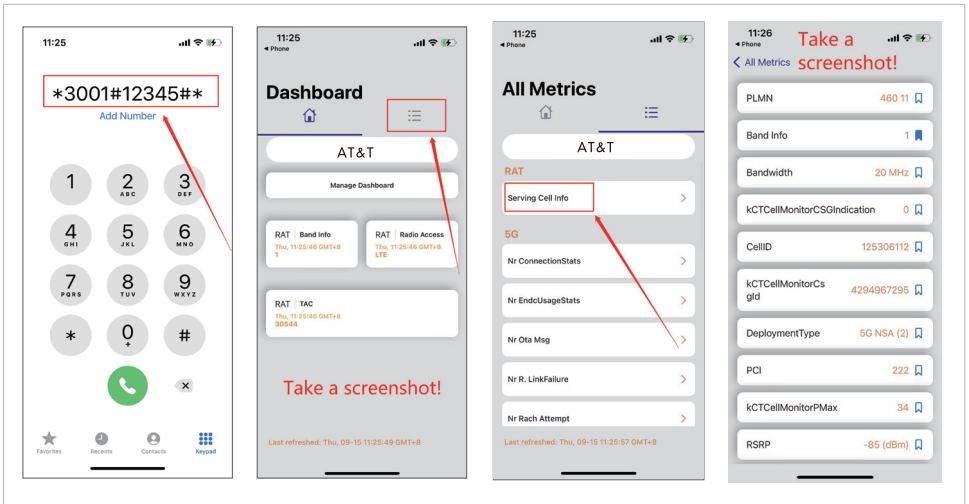

### 3.2 Find the cell tower

(1) Enter cellmapper.net

(2) Choose your own carrier and band here.

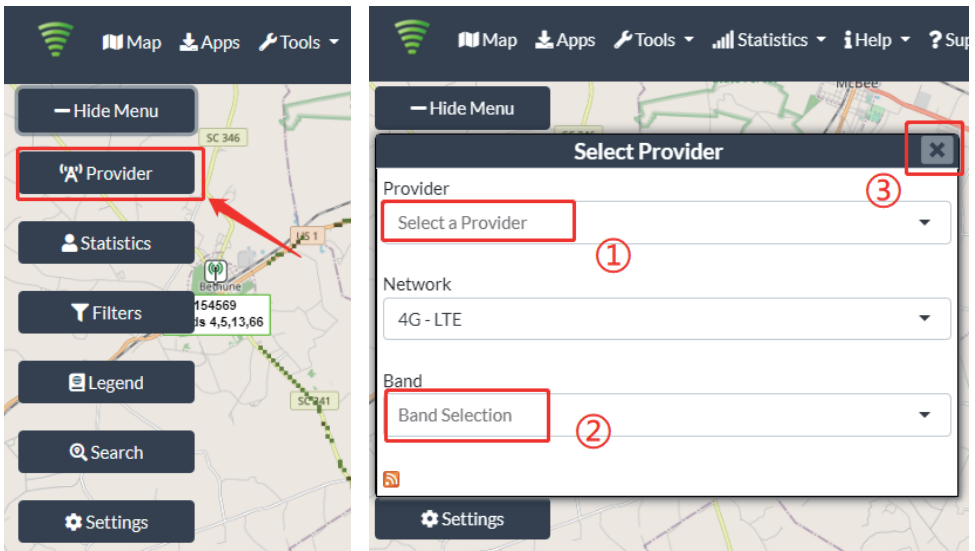



(3) Then enter the coordinate of where you are trying to install the signal booster, and press Enter key.

(In fact when you open Cellmapper, the map on the right will automatically locate your area if you've given the site permission to access your location.

If you found tower sites not even displayed on the map, it might be because the app intercepts the locations for security reasons.)

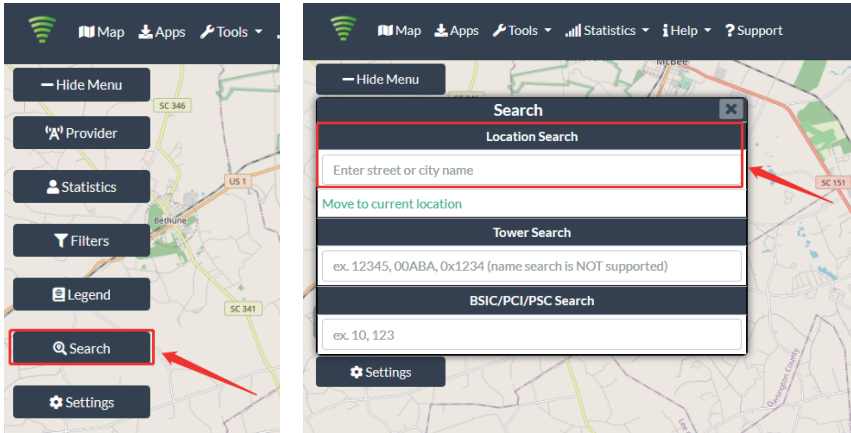

(4) After the map jumps to the location, you can scroll the mouse pulley and zoom it out, then you will see the tower near the location. It would be better to take a screenshot of this page to guide the following installation steps.

Should you have any questions, please contact our tech support.

Note: If you need help finding the tower, please contact our tech support and provide your carrier, band and screenshots taken in the last steps.

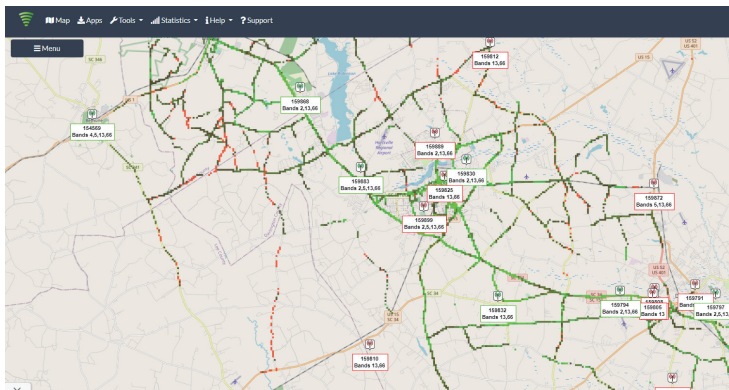

### 3.3 Determine the outdoor antenna's position

The outdoor antenna is usually placed at one of the 4 ends of the roof. Please choose the position according to the tower's location.

Make sure there are no barriers between the antenna and the tower.

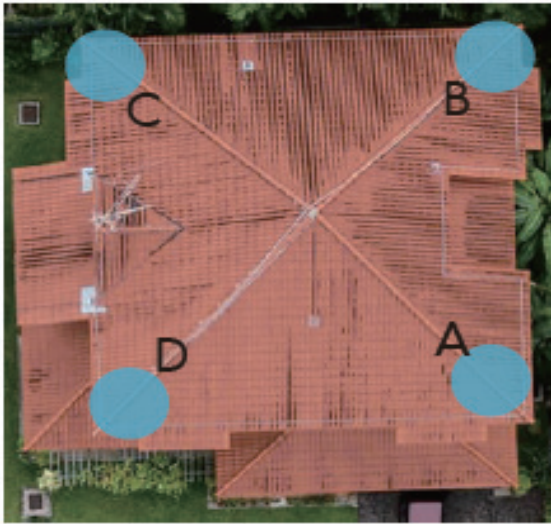

## Step 4 Install the outdoor antenna

### 4.1 Connect the outdoor antenna with the booster

- (1) Put the booster near to the location you would like to install in the future, or a place with power outlet temporarily.
- (2) Power on the booster and make sure the signal supervisor app links with it smoothly.
- (3) Connect the 16.4ft cable with the booster's outdoor port. The booster supports hot plug.
- (4) Then connect the window cable with 16.4ft cable and pull the window cable outside and connect it with 32.8ft cable. In case window cable is not needed, connect the 16.4ft cable with 32.8ft cable directly.
- (5) Connect the other side of 32.8ft cable with the outdoor antenna.

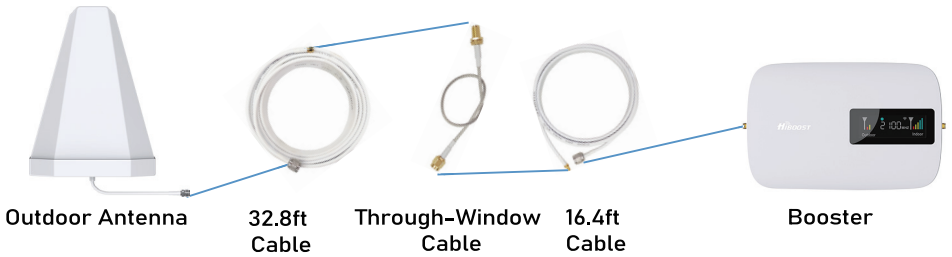

Notes:

\*Please do NOT connect indoor antenna at this moment as it will influence the outside signal finding.

\*Please place the booster within 30ft to the possible installation location of outdoor antenna if Bluetooth connection is applied. This is to ensure the App can connect to the booster.

#### 4.2 Adjust and fix the Outdoor Antenna

Have your outdoor antenna pointed to the cell tower you found before and observe the reading on the app. Adjust the outdoor antenna accordingly.



Notes:

(1) The output power should be the higher the better.

(2) The full output power for Hero is 10dBm. And the full gain is 65dB.

## Professional Tips

- Keep in mind that it is normal for the output values may vary dynamically between 1-3 dB.
- To optimize the signal for one carrier, point the outdoor antenna towards the closest cell phone tower designated to that carrier.
- To optimize the signal for more than one carrier, point the outdoor antenna between multiple towers.
- Make sure to slowly turn the antenna while taking the readings so the booster has time to adjust the reading.
- Test and install the antenna at the same height where power outputs and gain values reach the booster's maximum capacity.
- If you can't get a good output power, for instance, the value is below POOR level, it is highly likely that the installation will fail. Please either find a new place with better signal or drop the installation.

### 4.3 Install the outdoor antenna firmly

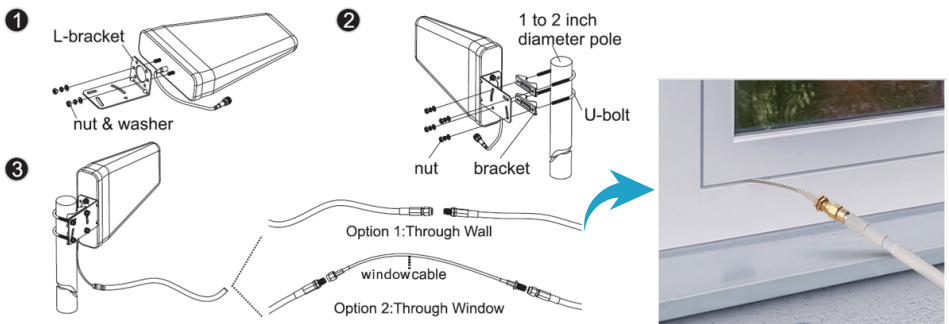

The connector of the cable connection part must be glued with black waterproof tape to prevent long-term signal drop and reduce signal loss!



#### 4.4 Reconfirm that the signal on signal gauge

Please **do take following screen shot** for future comparison during indoor antenna installation.

What you are going to be paying attention to here, is the gain values. If you have interference between your indoor and outdoor antennas, then the booster will lower the gain and these values will decrease.



### Step 5: Install the Indoor Antenna

There are 2 types of indoor antenna in kit Hero---whip antenna and panel antenna. You can choose either one to install.

Note: Compared with panel antenna, whip antenna, a kind of omnidirectional antenna, is not only less possible to cause loopback, but also easier to install. As for panel antenna, it is a bit more complicated to install, but usually has a better performance in covering signal.

#### 5.1 Desktop Mounted

1) Connect the indoor antenna with the booster



Indoor port

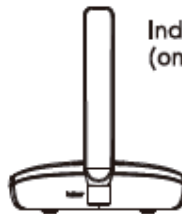

Indoor Whip Antenna  
(omnidirectional)

Connect the whip antenna to the Indoor port, and 13 feet lower in elevation, 30 feet separation between indoor whip antenna and outdoor antenna horizontally. (Put the booster where you would like to cover with signal.)

2) Install and adjust the indoor antenna

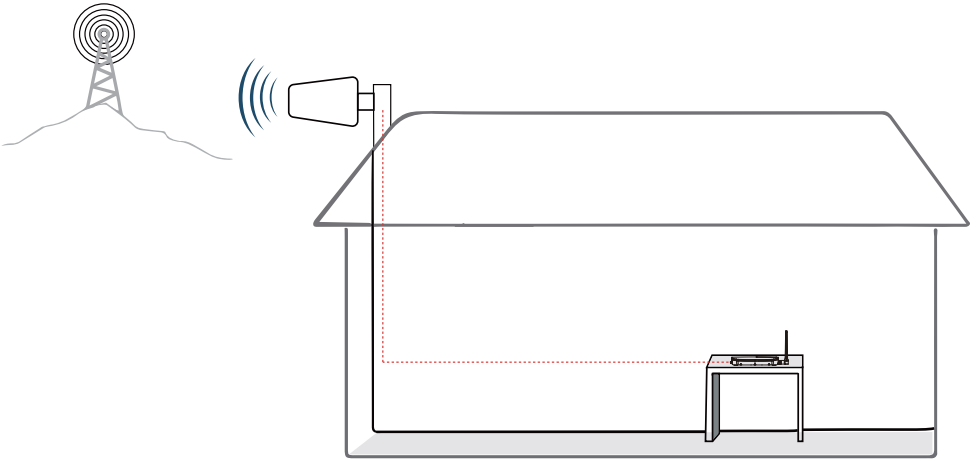

Put the signal booster on a dry and cool desktop, and it shall be easily accessible for maintenance.  
(As the whip antenna is a kind of omni antenna, it is suggested that the booster should be placed on a desk in the center of the area you would like to cover, rather than on a wall)

### 3) Adjust the indoor antenna

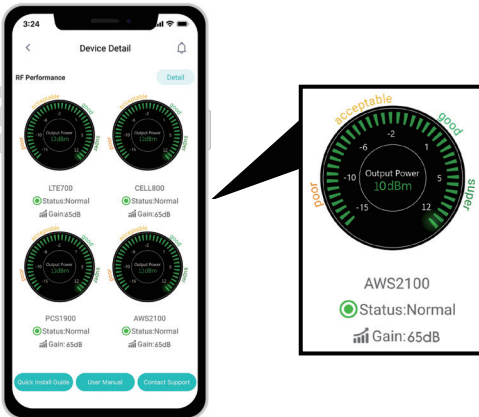

Note:

Make sure that the gain approaches 60dB. If not, please increase the vertical and horizontal distance between the two antennas or add some barriers.

#### 4) Signal quality test

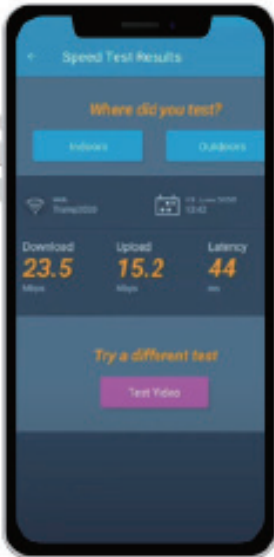

You could do the following:

- (1) First make sure the signal gauge value is unchanged from that during the outdoor antenna installation.
- (2) Do speed tests with the booster on and off, and make a comparison.
- (3) Check if the number of signal bars increases.
- (4) Make a phone call or send messages and check if the voice and streaming are better.

#### 5.2 Wall Mounted(Use Indoor Panel Antenna)

##### 1) Connect the indoor antenna with the booster

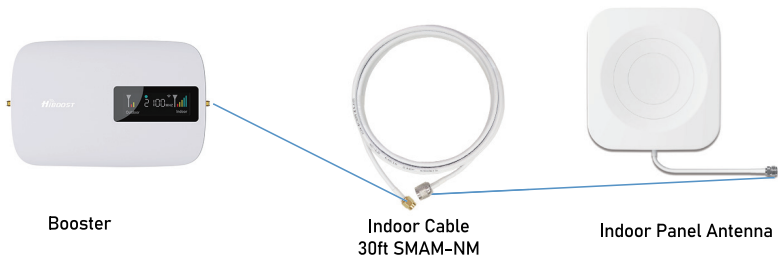

## 2) Adjust the indoor panel antenna

The radiation pattern is 80° horizontally and 70° vertically. So try to make sure your indoor antenna pointed to the area you would like to cover with signal.

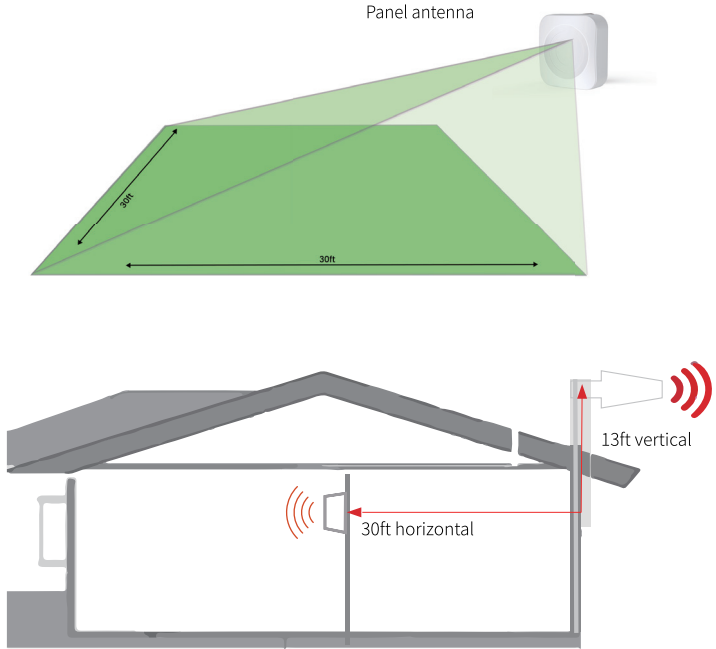

Notes:

It would be best if you could make the two antennas face opposite directions.

Make sure the gain reaches about 60dB. If not, please adjust the direction of the indoor antenna/ increase the vertical and horizontal distance between the two antennas/add some barriers.



### 3) Signal quality test

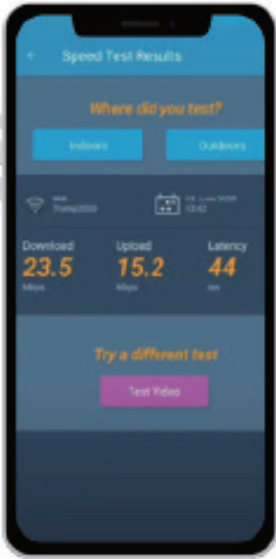

You could do the following:

- (1) First make sure the signal gauge value is unchanged from that during the outdoor antenna installation.
- (2) Do speed tests with the booster on and off, and make a comparison.
- (3) Check if the number of signal bars increases.
- (4) Make a phone call or send messages and check if the voice and streaming are better.

If the test is good, then congratulations, the indoor antenna position has been successfully found. Please install the indoor antenna.

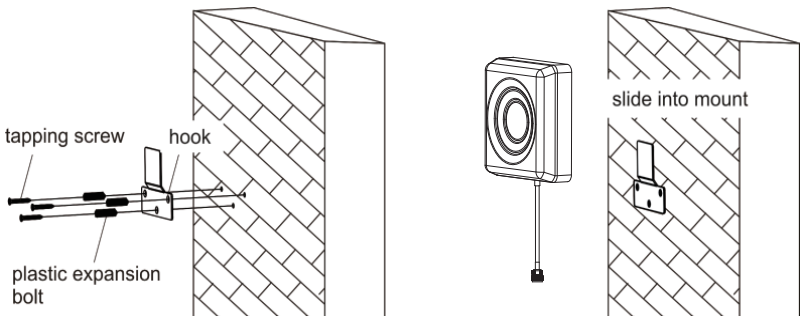

## Step 6: Install the booster and cables

If you choose panel antenna installation, please mount the signal booster in a dry and cool area, and it shall be easily accessible for maintenance.

And run the cables neatly, please do use the **water-proof tape** to protect all outside connections from the weather.

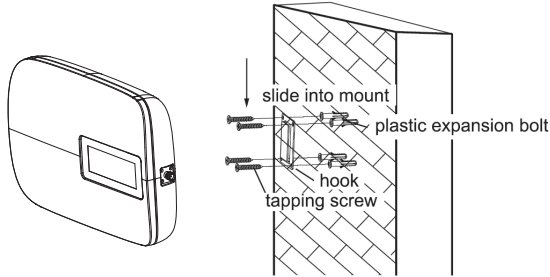

### Test again the performance after installation is done

- First make sure the Signal gauge value is unchanged from that during the outdoor antenna installation.
- Test with a third-party app, make sure calls and network data are smooth in most indoor signal coverage areas.

Now everything is completed and please start to enjoy the mobile services.

If the result is not satisfactory or you want to be better, you may repeat the whole or part of the process to improve.

Should you have any queries during the installation, please kindly contact us via Signal Supervisor App online support.

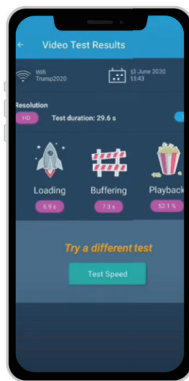
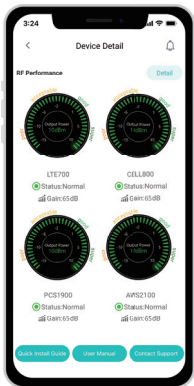

# LCD Assisted Installation

Flow chart of LCD Assisted Install

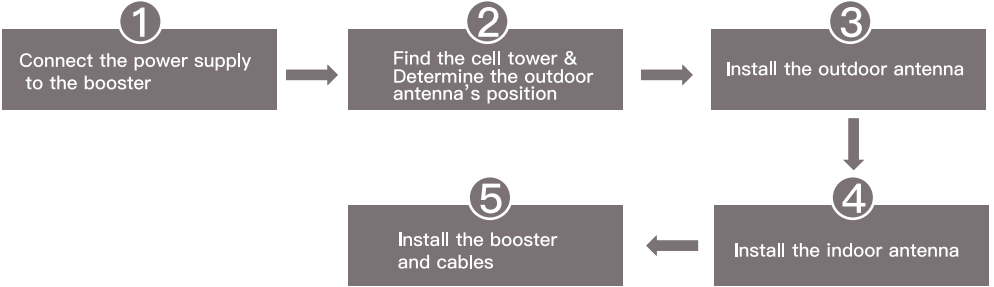

## Step 1: Connect the Power Supply to the Booster



Power Supply



Booster

## Step 2: Find the cell tower & Determine the outdoor antenna's position

### 2.1 Find the band you are using

For Android

Download NetWork Cell Info Lite in the Google store and open it.

It can be seen from the example picture that the frequency band is band 13.

(According to the form before, you need to pay attention to Gauge LTE700)

Then click MAP. You can see your phone connecting to a tower, and you can try aiming your outdoor antenna at it. But sometimes this is not accurate. You could also move to Step 3.2 to find the tower

Note: Please take screenshots at this stage.



For ios

(1)Dial \*3001#12345#\*

(2)Follow the instructions, take the screenshot as required.

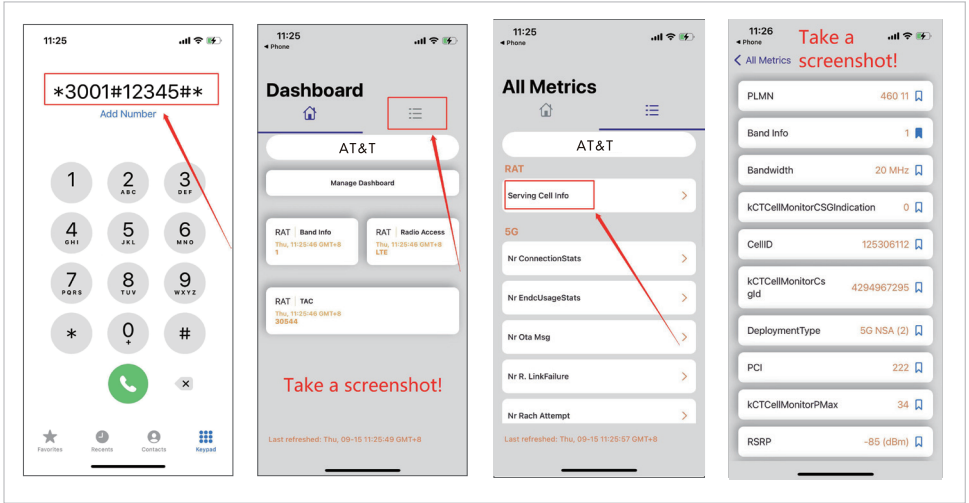

## 2.2 Find the cell tower

(1) Enter cellmapper.net

(2) Choose your own carrier and band here.

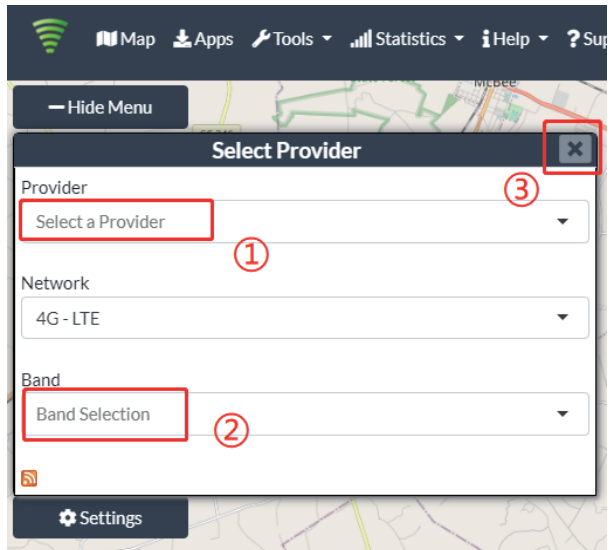
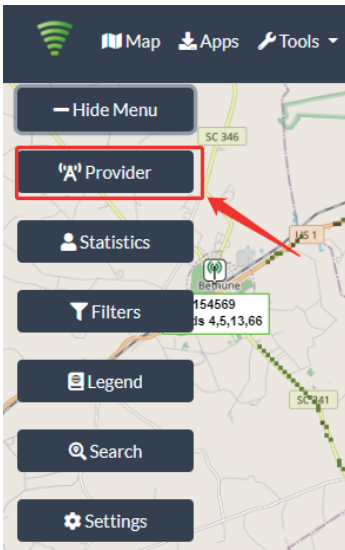

(3) Then enter the coordinate of where you are trying to install the signal booster, and press Enter key.

(In fact when you open Cellmapper, the map on the right will automatically locate your area if give the site permission to access your location.

If you found tower sites not even displayed on the map, it might because the app intercepts the locations for security reasons.)

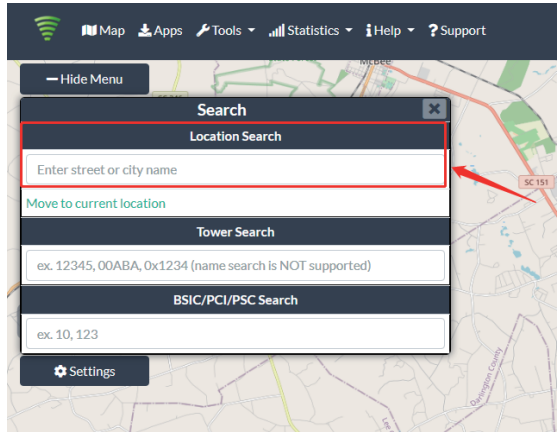
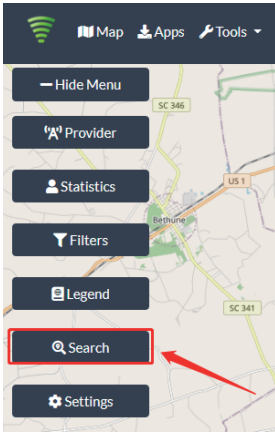

(4) After the map jumps to the location, you can scroll the mouse pulley and zoom it out, then you will see the tower near the location.

It would be better to take a screenshot of this page to guide the following installing steps. Should you have any questions, please contact our tech support.

Note: If you need help finding the tower, please contact our tech support and provide your carrier, band and screenshots taken in the last steps.

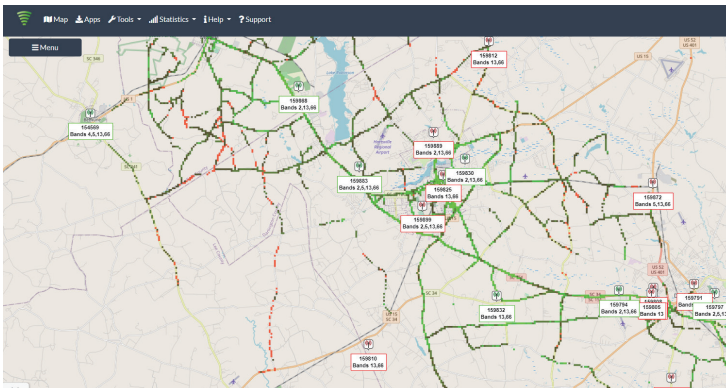

## 2.3 Determine the outdoor antenna's position

The outdoor antenna is usually placed at one of the 4 ends of the roof. Please choose the position according to the tower's location. Make sure there are no barriers between the antenna and the tower.

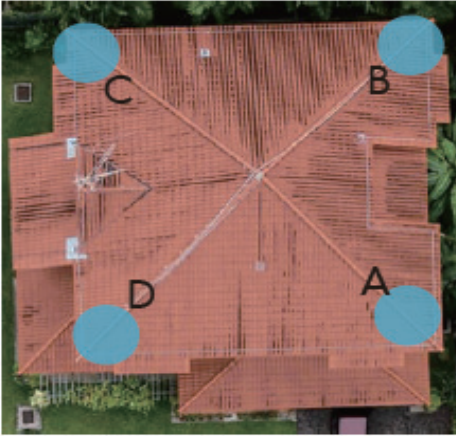

### Step 3 Install the outdoor antenna

3.1 Connect the outdoor antenna with the booster

- (1) Put the booster near to the location you would like to install in the future, or a place with power outlet temporarily.
- (2) Power on the booster and make sure the signal supervisor app links with it smoothly.
- (3) Connect the 16.4ft cable with the booster's outdoor port. The booster supports hot plug.
- (4) Then connect the window cable with 16.4ft cable and pull the window cable outside and connect it with 32.8ft cable. In case window cable is not needed, connect the 16.4ft cable with 32.8ft cable directly.
- (5) Connect the other side of 32.8ft cable with the outdoor antenna.

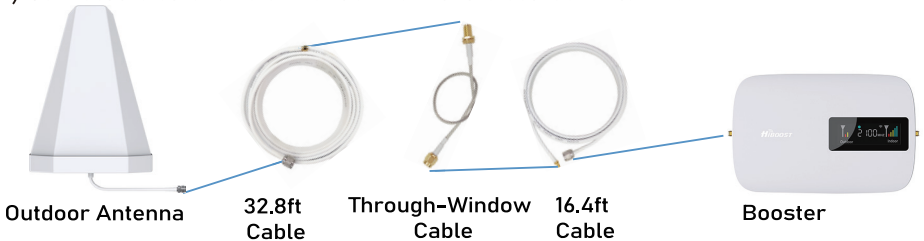

#### Notes:

\*Please do NOT connect indoor antenna at this moment as it will influence the outside signal finding.

\*Please place the booster within 30ft to the possible installation location of outdoor antenna if Bluetooth connection is applied. This is to ensure the App can connect to the booster.

### 3.2 Adjust the outdoor antenna

Now pick up the outdoor antenna and have it pointed to the above cell tower. Adjust its position accordingly while your partner is observing the LCD screen, then stop the adjustment until it gets the strongest indoor signal.

LCD signal meter tells how strong the signal is.



#### Professional Tips

- Keep in mind that it is normal that the number of indoor signal may slightly change from time to time
- To optimize the signal for one carrier, point the outdoor antenna towards the closest cell phone tower designated to that carrier
- To optimize the signal for more than one carrier, point the outdoor antenna between multiple towers
- Make sure to slowly turn the antenna so the booster has time to adjust the reading
- Test and install the antenna at the same height that the indoor signal reaches the booster's maximum capacity



### 3.3 Fix outdoor antenna

Now install the outdoor antenna firmly

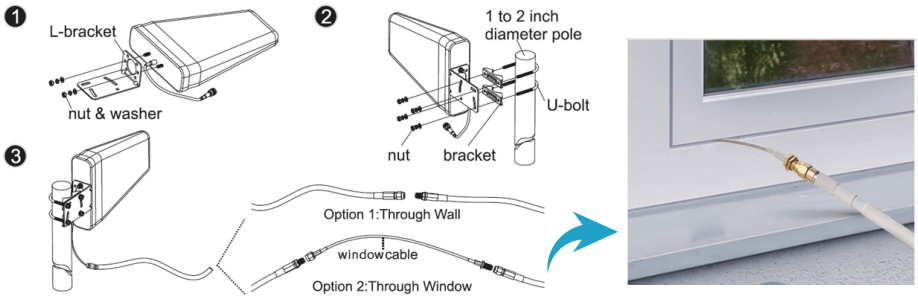

The connector of the cable connection part is glued with black waterproof tape to prevent long-term signal drop and reduce signal loss!



### 3.4 Reconfirm that the signal on LCD signal meter

Take a picture of LCD signal meter for future comparison during indoor antenna installation.

LCD signal meter tells how strong the signal is.



## Step 4: Install the indoor antenna

There are 2 types of indoor antenna in kit Hero—whip antenna and panel antenna. You can choose either one to install.

Note: Compared with panel antenna, whip antenna, a kind of omnidirectional antenna, is not only less possible to cause loopback, but also easier to install. As for panel antenna, it is a bit more complicated to install, but usually has a better performance in covering signal.

### 4.1 Choose either indoor antenna to install

#### a. Desktop Mounted

##### 1) Connect the indoor antenna with the booster



Indoor port

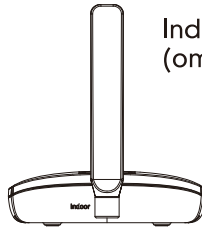

Indoor Whip Antenna  
(omnidirectional)

Connect the whip antenna to the Indoor port, and 13 feet lower in elevation, 30 feet separation between indoor whip antenna and outdoor antenna horizontally. (Put the booster where you would like to cover with signal.)

## 2) Install and adjust the indoor antenna

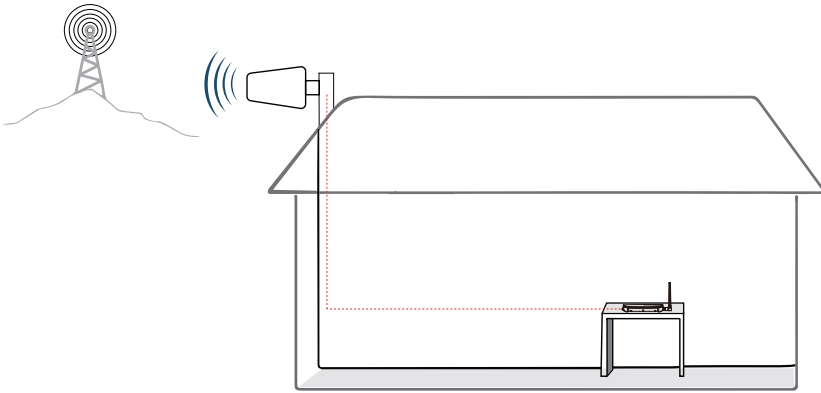

Put the signal booster on a dry and cool desktop, and it shall be easily accessible for maintenance.

(As the whip antenna is a kind of omni antenna, it is suggested that the booster should be placed on a desk in the center of the area you would like to cover, rather than on a wall)

### b. Wall Mounted (Use Indoor Panel Antenna)

#### 1) Connect the indoor antenna with the booster

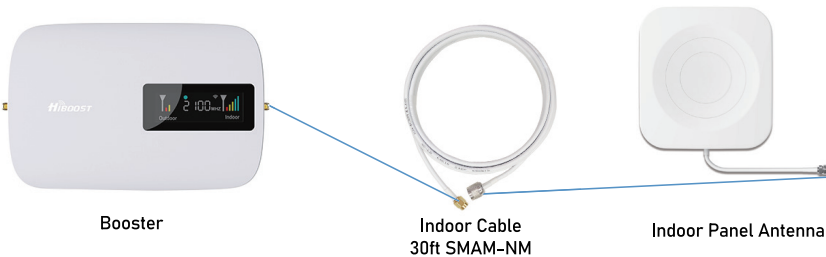

## 2) Adjust the indoor panel antenna

The radiation pattern is 80° horizontally and 70° vertically. So try to make sure your indoor antenna pointed to the area you would like to cover with signal.

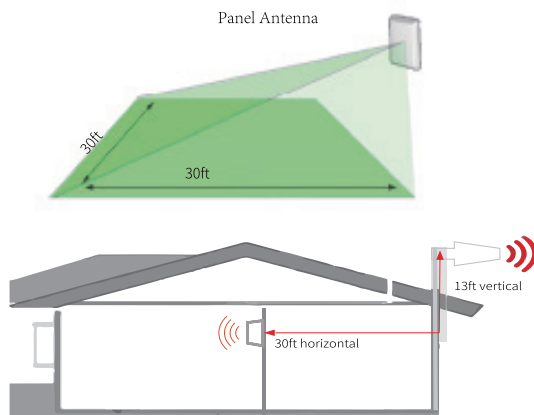

### Notes:

It would be best if you could make the two antennas face opposite directions. Make sure that the gain approaches 60dB. If not, please adjust the direction of the indoor antenna/increase the vertical and horizontal distance between the two antennas/add some barriers.

## 4.2 Observe the LCD screen

After finding the location, hold it there, and ask the other person to compare the outdoor signal and indoor signal on LCD screen, the signal strength shall keep the same or very close to the photo taken during outdoor antenna installation. This is to avoid loopback between outdoor and indoor antennas, please move the indoor antenna till you get unchanged or slightly-changed signal. **If there is a loopback, the gain will be decreased and shown on the booster and alarm light will blink.** This step is quite crucial for the booster's best performance.



## Two requests for indoor antenna installation

A. Radiation shall be good enough to cover whole space

B. Loopback shall be avoided

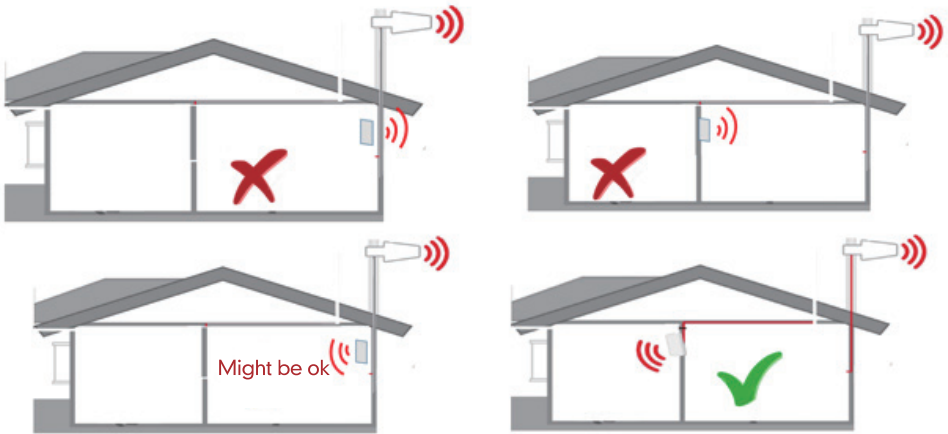

### Again the tips to avoid the loopback

1. Increase the distance between the outdoor and indoor antennas
2. The outdoor and indoor antennas shall face opposite directions (if you use the panel antenna as the indoor antenna)
3. Utilize barriers between the indoor and outdoor antennas

### 4.3 Signal Quality test

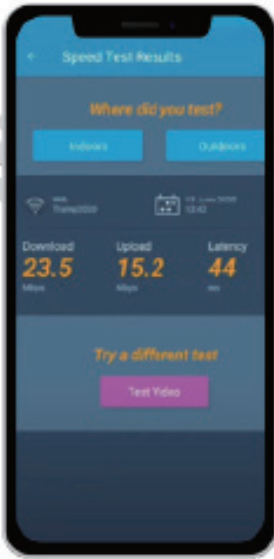

You could do the following:

- (1) First make sure the signal gauge value is unchanged from that during the outdoor antenna installation.
- (2) Do speed tests with the booster on and off, and make a comparison.
- (3) Check if the number of signal bars increases.
- (4) Make a phone call or send messages and check if the voice and streaming are better.

If the test is good, then congratulations, the indoor antenna position has been successfully found. Please install the indoor panel antenna.

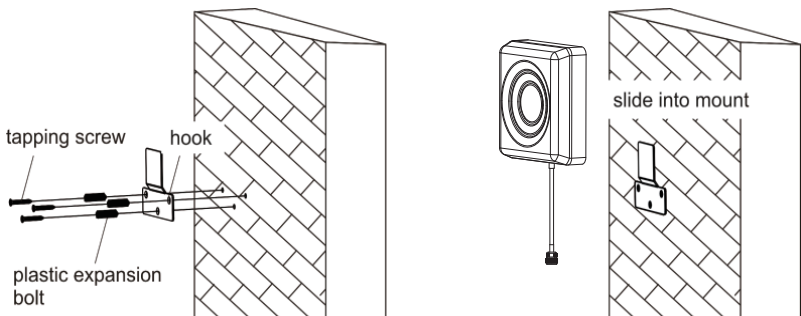

## Step 5: Install the booster and cables

If you choose panel antenna installation, please mount the signal booster in a dry and cool area, and it shall be easily accessible for maintenance.

And run the cables neatly, please do use the **water-proof tape** to protect all outside connections from the weather.

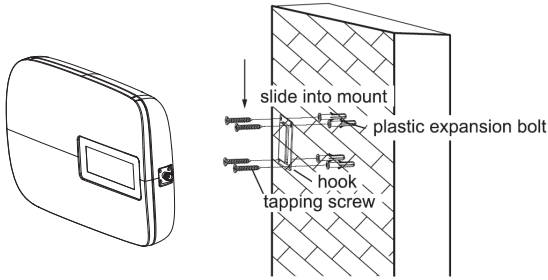

### Test again the performance after installation is done

- First make sure the Signal gauge value is unchanged from that during the outdoor antenna installation.
- Test with a third-party app, make sure calls and network data are smooth in most indoor

Now everything is completed and please start to enjoy the mobile services.

If the result is not satisfactory or you want to be better, you may repeat the whole or part of the process to improve.

Should you have any queries during the installation, please kindly contact us via Signal Supervisor App online support.

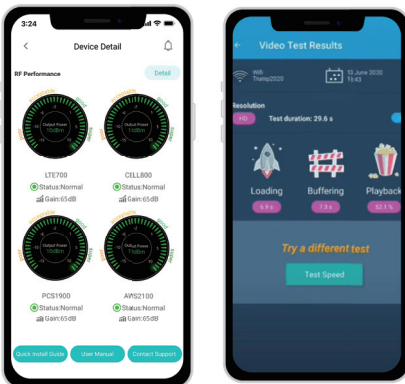

# Quick Troubleshooting Guide

If the booster is working normally, no further adjustment is required

| OVERLOAD |         |              |                                                |                              |                                                                     |
|----------|---------|--------------|------------------------------------------------|------------------------------|---------------------------------------------------------------------|
|          | DL GAIN | OUTPUT POWER | LED LIGHT PATTERN                              | REASON                       | SOLUTION                                                            |
| LTE700   | <60dB   | >=10dBm      | Alarm light flashing and Power light solid red | Outdoor signal is too strong | Have your outdoor antenna pointed slightly away from the cell tower |
| CELL800  | <60dB   | >=10dBm      |                                                |                              |                                                                     |
| PCS1900  | <60dB   | >=10dBm      |                                                |                              |                                                                     |
| AWS2100  | <60dB   | >=10dBm      |                                                |                              |                                                                     |

| LOOP BACK |         |              |                                                                                              |                                                          |                                                                                                                                                                                                                                                                         |
|-----------|---------|--------------|----------------------------------------------------------------------------------------------|----------------------------------------------------------|-------------------------------------------------------------------------------------------------------------------------------------------------------------------------------------------------------------------------------------------------------------------------|
|           | DL GAIN | OUTPUT POWER | LED LIGHT PATTERN                                                                            | REASON                                                   | SOLUTION                                                                                                                                                                                                                                                                |
| LTE700    | <60dB   | <10dBm       | Alarm light flashing and Power light solid red(strong loop back) or green( slight loop back) | Inadequate separation of the indoor and outdoor antennas | <ol style="list-style-type: none"> <li>1. Increase vertical and horizontal distance between the outdoor and indoor antenna(s).</li> <li>2. Make the outdoor antenna and the indoor antenna back to back.(panel antenna)</li> <li>3. Add barriers(e.g. walls)</li> </ol> |
| CELL800   | <60dB   | <10dBm       |                                                                                              |                                                          |                                                                                                                                                                                                                                                                         |
| PCS1900   | <60dB   | <10dBm       |                                                                                              |                                                          |                                                                                                                                                                                                                                                                         |
| AWS2100   | <60dB   | <10dBm       |                                                                                              |                                                          |                                                                                                                                                                                                                                                                         |

| POOR SIGNAL |         |              |                                             |                          |                                                                                                                                                                                                                                                                                                                                                                                                         |
|-------------|---------|--------------|---------------------------------------------|--------------------------|---------------------------------------------------------------------------------------------------------------------------------------------------------------------------------------------------------------------------------------------------------------------------------------------------------------------------------------------------------------------------------------------------------|
|             | DL GAIN | OUTPUT POWER | LED LIGHT PATTERN                           | REASON                   | SOLUTION                                                                                                                                                                                                                                                                                                                                                                                                |
| LTE700      | >=60dB  | --/NEGATIVE  | Alarm light OFF and power light solid green | Input signal is too weak | <ol style="list-style-type: none"> <li>1. Try adjusting the outdoor antenna to the best direction</li> <li>2. Try adjusting the outdoor antenna to another cell tower</li> <li>3. Try increasing the height of the outdoor antenna and make sure there are no barriers between the tower and the outdoor antenna</li> </ol> Please try these solutions until the output power reaches or is over -5dBm. |
| CELL800     | >=60dB  | --/NEGATIVE  |                                             |                          |                                                                                                                                                                                                                                                                                                                                                                                                         |
| PCS1900     | >=60dB  | --/NEGATIVE  |                                             |                          |                                                                                                                                                                                                                                                                                                                                                                                                         |
| AWS2100     | >=60dB  | --/NEGATIVE  |                                             |                          |                                                                                                                                                                                                                                                                                                                                                                                                         |



| Normal but No Boosted Signal |         |              |                                             |                                                                      |                                                                                                                                                                                                                                                                                                                              |
|------------------------------|---------|--------------|---------------------------------------------|----------------------------------------------------------------------|------------------------------------------------------------------------------------------------------------------------------------------------------------------------------------------------------------------------------------------------------------------------------------------------------------------------------|
|                              | DL GAIN | OUTPUT POWER | LED LIGHT PATTERN                           | REASON                                                               | SOLUTION                                                                                                                                                                                                                                                                                                                     |
| LTE700                       | >=60dB  | >=-5dBm      | Alarm light OFF and power light solid green | 1. The band is not supported<br>2. The Signal is from other Carriers | Check the band you are using again. If it stays at band66, get into the 'detail'/'Setting' of gages on Signal Supervisor and switch off RF switch of AWS2100, then adjust the outdoor antenna again. It would be better if there are two persons and one can stay near the indoor antenna to check if the signal is boosted. |
| CELL800                      | >=60dB  | >=-5dBm      |                                             |                                                                      |                                                                                                                                                                                                                                                                                                                              |
| PCS1900                      | >=60dB  | >=-5dBm      |                                             |                                                                      |                                                                                                                                                                                                                                                                                                                              |
| AWS2100                      | >=60dB  | >=-5dBm      |                                             |                                                                      |                                                                                                                                                                                                                                                                                                                              |

| NORMAL  |         |              |                                             |        |          |
|---------|---------|--------------|---------------------------------------------|--------|----------|
|         | DL GAIN | OUTPUT POWER | LED LIGHT PATTERN                           | REASON | SOLUTION |
| LTE700  | >=60dB  | >=-5dBm      | Alarm light OFF and power light solid green |        |          |
| CELL800 | >=60dB  | >=-5dBm      |                                             |        |          |
| PCS1900 | >=60dB  | >=-5dBm      |                                             |        |          |
| AWS2100 | >=60dB  | >=-5dBm      |                                             |        |          |

**Note:**  
 Some customers have some misunderstandings about boosters, and we would like to clarify it here:  
 If you can't even get a stable 1 bar outside the house or on the roof, then we suggest you return it as it won't work in areas with very weak signal, the same is true of all boosters on the market.

## Technical Specifications

| Model No.               | Hero                                                                  |
|-------------------------|-----------------------------------------------------------------------|
| Working Band            | Band 12-17 / Band 13 / Band 5 / Band 25-2 / Band 4                    |
| UL Frequency Range(MHz) | 698-716 / 776 – 787 / 824-849 / 1850-1915 / 1710-1755                 |
| DL Frequency Range(MHz) | 728-746 / 746 – 757 / 869-894 / 1930-1995 / 2110-2155                 |
| Supported Standards     | CDMA, WCDMA, GSM, EDGE, HSPA+, EVDO, LTE, 5G and all cellular standar |
| Max. Gain               | 65 dB                                                                 |
| Max. output power       | DL 10 dBm                                                             |
| MGC (Step Attenuation ) | ≥ 25 dB / 1 dB step                                                   |
| I/O Port                | SMA-Female                                                            |
| Impedance               | 50 ohm                                                                |
| Environment Conditions  | IP40                                                                  |
| Dimensions              | 7.6*5*1.3 in / 192*126*33mm                                           |
| Weight                  | ≤ 1.68 lbs / 0.76 kg                                                  |
| Power Supply            | Input AC100~240 V, 50/60 Hz, Output DC 12 V / 3 A                     |

**Notes:** Support 5G only that's been or will be deployed in current 4G by DSS (Dynamic Spectrum Sharing) by carriers.

# Authorized Accessories List

## Outdoor Antenna & Cable Kit Options

### Kit 9-5050

Yagi 9dbi Antenna & 50' 5D Cable

### Kit 11-100400

Yagi 11dbi Antenna & 100' 400 Cable

### Kit 11-7550

Yagi 11dbi Antenna & 75' 5D Cable

### Kit 11-100500

Yagi 11dbi Antenna & 100' 5D Cable

### Kit 10-3050

Panel 10dbi Antenna & 30' 5D Cable

### Kit 10-50400

Panel 10dbi Antenna & 50' 400 Cable

### Kit 10-5050

Panel 10dbi Antenna & 50' 5D Cable

### Kit 10-75400

Panel 10dbi Antenna & 75' 400 Cable

### Kit 10-100400

Panel 10dbi Antenna & 100' 400 Cable

### Kit 10-7550

Panel 10dbi Antenna & 75' 5D Cable

### Kit 10-10050

Panel 10dbi Antenna & 100' 5D Cable

### Kit 9-50400

Yagi 9dbi Antenna & 50' 400 Cable

### Kit 9-75400

Yagi 9dbi Antenna & 75' 400 Cable

### Kit 9-100400

Yagi 9dbi Antenna & 100' 400 Cable

### Kit 9-7550

Yagi 9dbi Antenna & 75' 5D Cable

### Kit 9-10050

Yagi 9dbi Antenna & 100' 5D Cable

### Kit 7-3050

Panel 7dbi Antenna & 30' 5D Cable

### Kit 7-50400

Panel 7dbi Antenna & 50' 400 Cable

### Kit 7-5050

Panel 7dbi Antenna & 50' 5D Cable

### Kit 7-75400

Panel 7dbi Antenna & 75' 400 Cable

### Kit 7-100400

Panel 7dbi Antenna & 100' 400 Cable

### Kit 7-7550

Panel 7dbi Antenna & 75' 5D Cable

### Kit 7-10050

Panel 7dbi Antenna & 100' 5D Cable

### Kit 5-30400

Omni 5dbi Antenna & 30' 400 Cable

### Kit 5-3050

Omni 5dbi Antenna & 30' 5D Cable

### Kit 5-50400

Omni 5dbi Antenna & 50' 400 Cable

### Kit 5-5050

Omni 5dbi Antenna & 50' 5D Cable

### Kit 5-75400

Omni 5dbi Antenna & 75' 400 Cable

### Kit 5-10400

Omni 5dbi Antenna & 100' 400 Cable

### Kit 5-7550

Omni 5dbi Antenna & 75' 5D Cable

### Kit 5-10050

Omni 5dbi Antenna & 100' 5D Cable

## Indoor Antenna & Cable Kit Options

### Kit 72-5050-50

2 Panel 7dbi Antenna with 50' 5D N male  
& 2-Way Splitter

### Kit 52-5050-50

2 Whip 5dbi Antenna & 50' 5D Cable  
& 2-Way Splitter

### Kit 102-5050-50

2 Panel 10dbi Antenna with 50' 5D N male  
& 2-Way Splitter

### Kit 103-7550-50

3 Panel 10dbi Antenna & 75' 5D Cable  
& 3-Way Splitter

### Kit 104-7550-50

4 Panel 10dbi Antenna & 75' 5D Cable  
& 3 2-Way Splitter

### Kit 73-7550-50

3 Panel 7dbi Antenna & 75' 5D Cable  
& 3-Way Splitter

### Kit 74-7550-50

4 Panel 7dbi Antenna & 75' 5D Cable  
& 3 2-Way Splitter

### Kit 3-30400

Omni 3dBi Antenna with 30' 400 Cable

### Kit 3-5050

Omni 3dBi Antenna & 50' 5D Cable

### Kit 3-7550

Omni 3dBi Antenna & 75' 5D Cable

### Kit 3-10050

Omni 3dBi Antenna & 100' 5D Cable

### Kit 3-30400

Omni 3dBi Antenna with 30' 400 Cable

### Kit 3-50400

Omni 3dBi Antenna & 50' 400 Cable

### Kit 32-50400-50

20 Omni 3dBi Antenna & 50' 400 Cable  
& 2-Way Splitter

### Kit 33-50400-50

3 Omni 3dBi Antenna & 50' 400 Cable  
& 3-Way Splitter

### Kit 34-50400-50

4 Omni 3dBi Antenna & 50' 400 Cable  
& 3 2-Way Splitter

# FCC and IC Statements

## FCC RF EXPOSURE STATEMENT

This equipment complies with FCC radiation exposure limits set forth for an uncontrolled environment. End users must follow the specific operating instruction for satisfying RF exposure compliance. This transmitter must not be colocated or operating in conjunction with any other antenna or transmitter.

## IC RF EXPOSURE STATEMENT

The device is in compliance with RF exposure limits. The minimum distance from body to use the device is 20 CM.

Le présent appareil est conforme aux normes de conformité ou aux limites d'intensité de champ RF. La distance minimale du corps à utiliser le dispositif est de 20 CM.

This equipment has been tested and found to comply with the limits for a Class B digital device, pursuant to part 15 of the FCC Rules. These limits are designed to provide reasonable protection against harmful interference in a residential installation. This equipment generates, uses and can radiate radio frequency energy and, if not installed and used in accordance with the instructions, may cause harmful interference to radio communications. However, there is no guarantee that interference will not occur in a particular installation. If this equipment does cause harmful interference to radio or television reception, which can be determined by turning the equipment off and on, the user is encouraged to try to correct the interference by one or more of the following measures:

- Re-orient or relocate the receiving antenna.
  - Increase the separation between the equipment and receiver
  - Connect the equipment into an outlet on a circuit different from that to which the receiver is connected
  - Consult the dealer or an experienced radio/TV technician for help
- Changes or modifications not expressly approved by HiBoost could void the user's authority to operate the equipment. For a complete list of antennas and cables approved for use with these boosters see Authorized Kitting Options

**FCC 27.50(d)(4) Statement:** Fixed, mobile, and portable (handheld) stations operating in the 1710-1755 MHz band are limited to 1-watt EIRP. Fixed stations operating in the 1710-1755 MHz band are limited to a maximum antenna height of 10 meters above ground.

**FURTHER INFORMATION ON SIGNAL BOOSTER END-USE REGISTRATION**

The following links are the currently active contacts for booster registration with U.S. wireless providers:

<https://www.uscellular.com/uscellular/support/fcc-booster-registration.jsp>

[https://www.sprint.com/legal/fcc\\_boosters.html](https://www.sprint.com/legal/fcc_boosters.html)

<https://www.verizonwireless.com/solutions-and-services/accessories/register-signal-booster/> <https://support.t-mobile.com/docs/DOC-9827>

<https://secure45.securewebsession.com/attsignalbooster.com/>

**IC Statement:** This device complies with Innovation, Science and Economic Development Canada ICES-003 Compliance Label: CAN ICES-3 (B)/NMB-3(B). Le présent appareil est conforme Innovation, science et développement économique Canada ICES-003 Étiquette de conformité: CAN ICES-3 (B) / NMB-3 (B).

Please follow the link to access the CPC-2-1-05:

This is a CONSUMER device.

**BEFORE USE**, you **MUST REGISTER THIS DEVICE** with your wireless provider and have your provider’s consent. Most wireless providers consent to the use of signal boosters. Some providers may not consent to the use of this device on their network.If you are unsure, contact your provider.

In Canada, **BEFORE USE**, you must meet all requirements set out in ISED CPC-2-1-05.

You **MUST** operate this device with approved antennas and cables as specified by the manufacturer. Antennas **MUST** be installed least 20 cm(8 inches)from(i. e..**MUST NOT** be installed within 20 cm of)any person.

You **MUST** cease operating this device immediately if requested by the FCC(or ISED in Canada)or a licensed wireless service provider.

**WARNING.** E911 location information may not be provided or may be inaccurate for calls served by using this device.

This device may be operated ONLY in a fixed location(i.e., may operate in a fixed location only )for in-building use.

## Return and Warranty Policies

**30-Day Money-Back Guarantee:** If for any reason the performance of any product is not acceptable, the product may be returned to the reseller within 30-days with proof of purchase. Please contact the customer support team.

**3-Year Warranty:** Signal boosters and kits are warranted for 3 years. We will repair or replace the unit and will cover the cost of delivery back to consumers located within the continental US and Canada. We will only cover shipping to our office if the booster was delivered to you recently, and was delivered defective.

Customers can choose to return the signal boosters and kits directly to the manufacturer at the purchaser's expense with a dated proof of purchase and a Returned Material Authorization (RMA) number supplied by us. RMA numbers may be obtained by contacting customer support at 972-870- 5666 or support @hiboost.com

This warranty does not apply to any signal boosters or kits determined by us to have been subjected to tampering, misuse, abuse, neglect, or mishandling that alters or damages physical or electronic properties.

We are not liable for any Signal Supervisor application network connectivity issues. The cell phone signal booster relies on a strong, continuous and reliable connection to the internet in order to communicate with the cell phone application. For all Signal Supervisor Application related issues, please check your network strength and call our technical support.

Failure to use a surge-protected AC power strip with at least a 1000 Joule rating will void your warranty. Damage caused by lightning is not covered by this warranty.

All of the products that are packaged with other accessory products are intended for resale and used as a single integrated system. Such product kits are required to be sold to the end-users or subsequent reseller as packaged.